

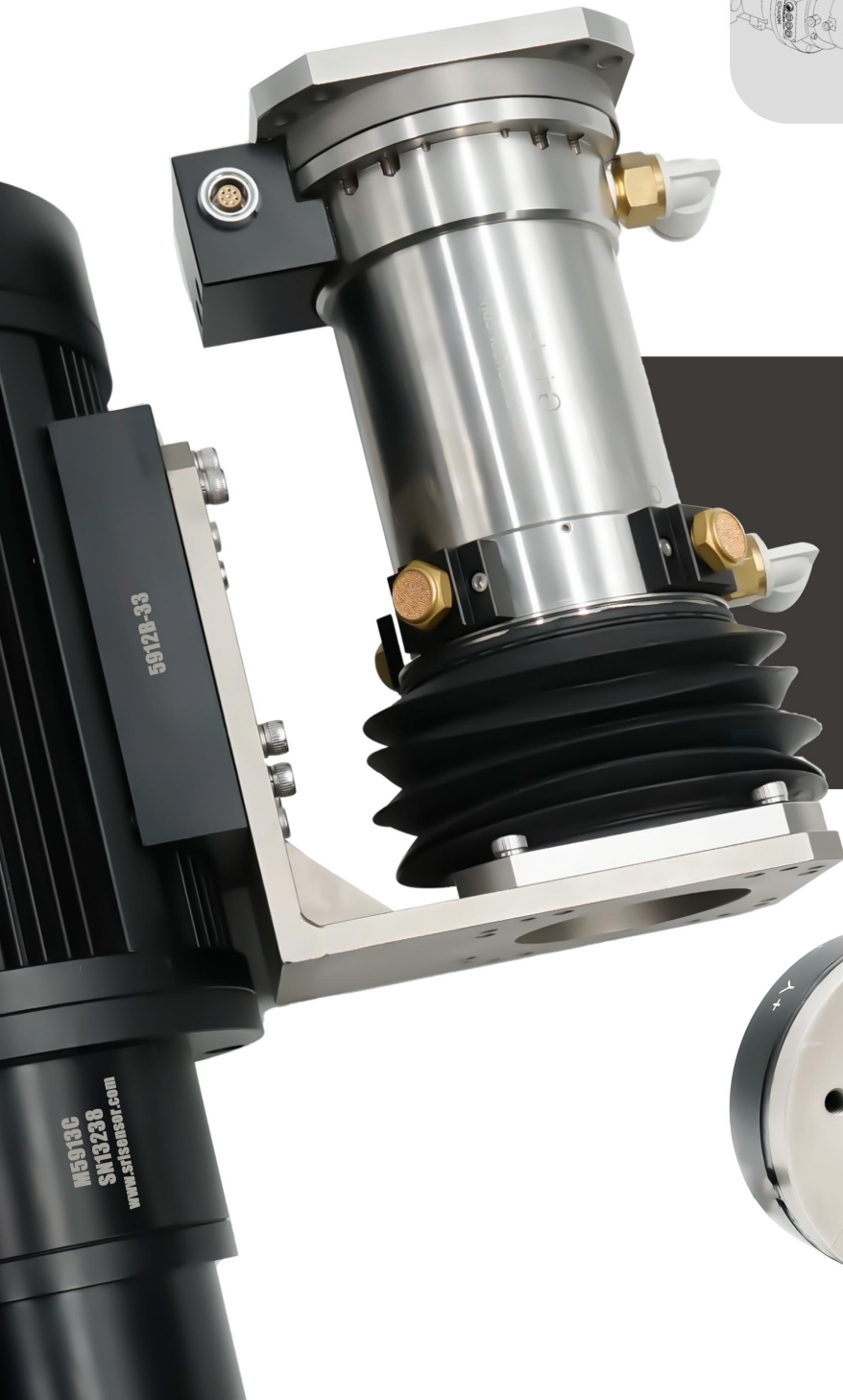

Sunrise Instruments 2023 Product catalog

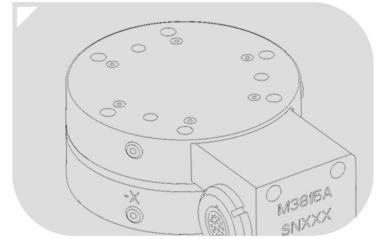

6 Axis F/T Sensor

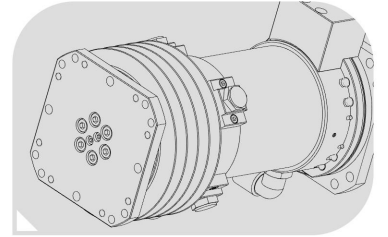
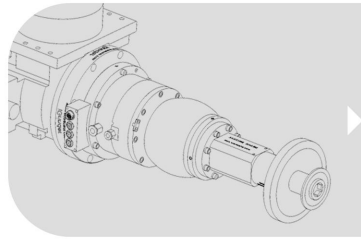

Robot Joint Torque Sensor



Intelligent Floating Grinder



Sunrise Instruments

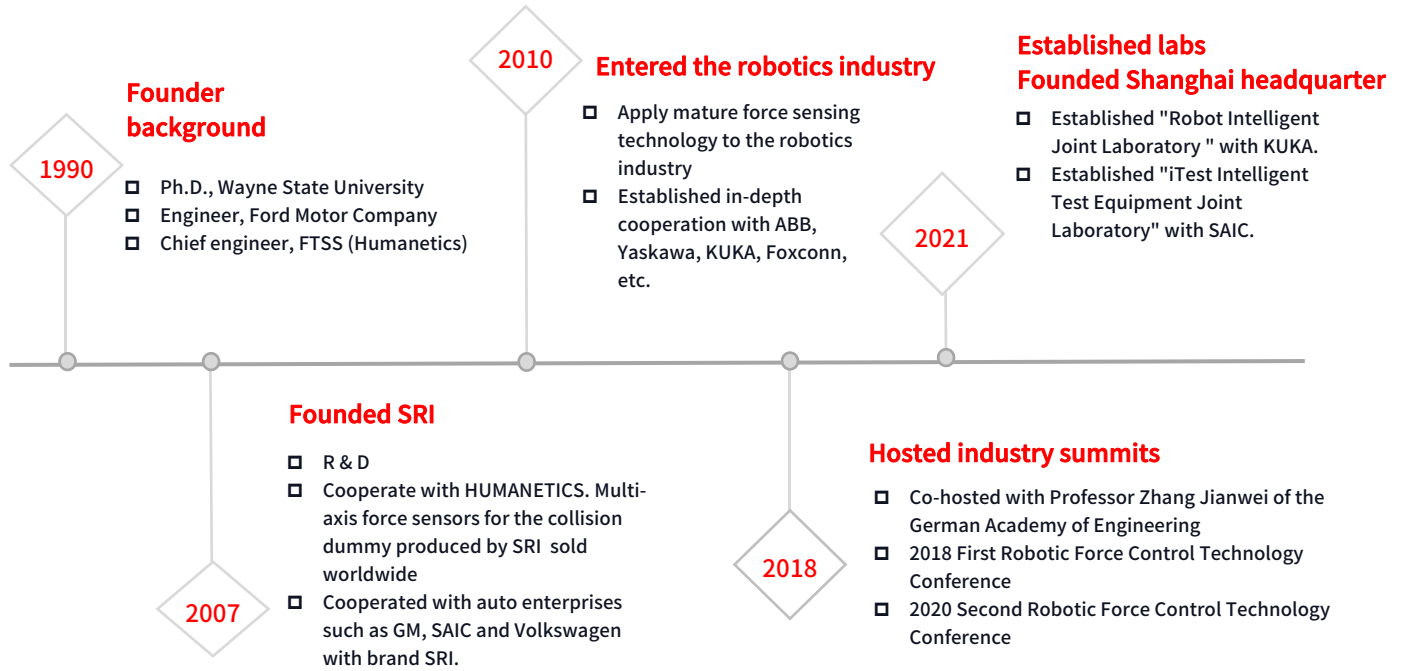

- Founder Dr.York Huang is the former chief engineer of FTSS (Humanetics ATD).
- SRI is a technology-intensive company integrating R&D and production. It has a number of patents and qualification certifications. With rich experience in robot force control applications, SRI has successfully launched the intelligent floating grinding head-- iGrinder.
- SRI is one of the few in the world that has a self-developed production line of automotive crash simulation dummy sensors.
- SRI customers are located all over the world, coming from various fields such as automotive, robotic automation and medical. Key clients include most of the world's automotive companies, Medtronic, ABB, KUKA, YASKAWA, and top university and research labs.

Main Products

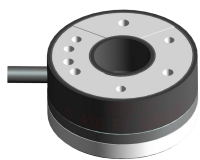

6 axis F/T load cell

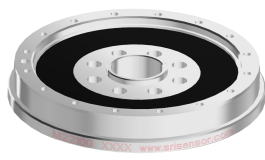

Joint torque sensor



iGrinder intelligent floating head



Automotive testing sensor

SRI Selection Guide



6 axis Force/Torque Sensor

M37XX series: Universal 6 axis F/T load cell for general testing.

M33XX series: 6 axis F/T sensor for industrial robotic application, 10X overload.

M43XX series: 6 axis F/T sensor for industrial robotic application.

M35XX series: Low profile 6 axis F/T load cell for applications with limited space. Less than 9.2mm height.

M38XX series: 6 axis F/T sensor for low capacity & high accuracy, accuracy within 0.2% of full scale, suitable for medical robots and precision assembly, etc.

M39XX series: Large capacity 6 axis F/T sensor. The capacity range is up to 300KN.

M361X series: 6 axis training force measuring platform for medical rehabilitation, sports, etc.



Torque Sensor (Torque Transducer)

Torque sensors are used to measure the output torque of the motor/reducer and has the advantages of high precision, thin thickness, light weight, high rigidity and strong bending resistance.

M22XX series: Torque Transducers for Robotic Joints.

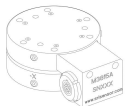

Uniaxial and Special Load Cell

SRI offers uniaxial force load cell and special force load cell for specialty applications.

M21XX series: Uniaxial force load cell

M36XX series: Specialty force load cell



Data Acquisition System & Signal Amplifier

M812X series / M830X series

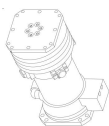

iGrinder® Intelligent Floating Head

iGrinder® is an independent force-controlled grinding system and does not rely on robot force-controlled software. When it is used with the robot for grinding, polishing and other applications, the user only needs to input the required force value to the iGrinder® which can then complete the force control and floating functions by itself. The robot only has to follow the intended path and does not have to execute its own force sensing or force control. This way, the intelligent force controlled grinding can be realized easily.

Axial Floating Grinding Head Series: axial floating force control, axial floating grinding head combination tool.

Radial Floating Grinding Head Series: heavy-duty radial floating grinding head, replaceable radial floating grinding head, radial floating deburring tool.

SIX



6 Axis F/T Sensor

SRI is a world leading supplier of 6 axis force sensors. SRI has an office in Michigan, United States, distributors in Korea and Taiwan, and customers all over the world.

SRI sensors are 100% designed, manufactured and calibrated in house, and has the world's leading production line of automotive crash dummy sensors. SRI's quality system is ISO9001 certified, and the calibration laboratory is ISO17025 certified.

SRI 6 axis force sensor includes 9 series, from 1 axis to 6 axis, and more than 300 models.

APPLICATIONS



Robotic automation



Auto crash & durability testing



Biomechanics



General testing

M37XX Series 6 Axis F/T Sensor for Robotics & General Testing

37XX series 6 axis force/torque sensors are matrix-decoupled, diameters from 15mm to 135mm, capacities from 50 to 6400N, 0.5 to 320Nm, non-linearity & hysteresis 0.5%, crosstalk 2% and overload 300%. A 6X6 decoupling matrix is provided in the calibration sheet when delivered. The amplifier (M830X) can be used to provide high voltage output. The interface box (M812X) can be used to provide signal conditioning and data acquisition. Amplifiers can be embedded into some of the sensors at special request. Standard protection is IP60. Some of the 37XX models can be made to IP68 (10m underwater), denoted by "P" in the part number (e.g. M37162BP).

Model	Description	Measurement Range(N/Nm)				Dimension (mm)			Weight (Kg)
		FX,FY	FZ	MX,MY	MZ	OD	Height	ID	
M3701A	6 AXIS LOADCELL D15MM F50N	50	100	0.5	0.5	15	14	4.4	0.01
M3701B	6 AXIS LOADCELL D15MM F100N	100	200	1	1	15	14	4.4	0.01
M3701C	6 AXIS LOADCELL D15MM F200N	200	400	2	2	15	14	4.4	0.01
M3702A	6 AXIS LOADCELL D21MM F50N	50	100	0.75	0.75	21	17	5.4	0.01
M3702B	6 AXIS LOADCELL D21MM F100N	100	200	1.5	1.5	21	17	5.4	0.01
M3702C	6 AXIS LOADCELL D21MM F200N	200	400	3	3	21	17	5.4	0.01
M3702C1	6 AXIS LOADCELL D21MM F200N, CENTER	200	400	3	3	21	17	*	0.01
M3712A	6 AXIS LOADCELL D21MM F400N	400	800	6	6	21	17	5.4	0.02
M3712A1	6 AXIS LOADCELL D21MM F400N, CENTER	400	800	6	6	21	17	*	0.02
M3712B	6 AXIS LOADCELL D21MM F800N	800	1600	12	12	21	17	5.4	0.02
M3722C	6 AXIS LOADCELL D30MM F1600N	1600	3200	40	40	30	23	6	0.07
M3722F	3 AXIS LOADCELL D30MM F5000N	5000	10000	NA	NA	30	58	*	0.10
M3733C	6 AXIS LOADCELL D35MM F120N	120	200	5	5	35	19	7	0.04
M3703A	6 AXIS LOADCELL D45MM F50N	50	100	1.75	1.75	45	19	17	0.04
M3703B	6 AXIS LOADCELL D45MM F100N	100	200	3.5	3.5	45	19	17	0.04
M3703B2	6 AXIS LOADCELL D45MM F100N	100	200	5	5	45	19	17	0.04
M3703C	6 AXIS LOADCELL D45MM F200N	200	400	7	7	45	19	17	0.04
M3713A	6 AXIS LOADCELL D45MM F400N	400	800	14	14	45	19	17	0.10
M3713A1	6 AXIS LOADCELL D45MM F400N, CENTER	400	800	14	14	45	19	17	0.10
M3713B	6 AXIS LOADCELL D45MM F800N	800	1600	28	28	45	19	17	0.11
M3713C	6 AXIS LOADCELL D45MM F1600N	1600	3200	56	56	45	19	17	0.11
M3713D	6 AXIS LOADCELL D45MM F3200N	3200	6400	112	112	45	19	17	0.11
M3704B	6 AXIS LOADCELL D70MM F100N	100	200	5.5	5.5	70	23	30	0.12
M3704C	6 AXIS LOADCELL D70MM F200N	200	400	11	11	70	23	30	0.12
M3704C1	6 AXIS LOADCELL D70MM F200N, CENTER	200	400	11	11	70	23	30	0.12
M3704C2	6 AXIS LOADCELL D70MM F200N, AMP	200	400	11	11	70	23	*	0.12
M3714A	6 AXIS LOADCELL D70MM F400N	400	800	22	22	70	23	30	0.29
M3714B	6 AXIS LOADCELL D70MM F800N	800	1600	44	44	70	23	30	0.29
M3714B1	6 AXIS LOADCELL D70MM F800N	900	1800	50	50	70	23	*	0.32
M3714B4	6 AXIS LOADCELL D60MM F900N	900	1800	100	100	60	23	*	0.24
M3714B5	6 AXIS LOADCELL D70MM F900N	900	1800	100	100	70	23	*	0.32
M3714C	6 AXIS LOADCELL D70MM F1600N	1600	3200	88	88	70	23	30	0.29

M37XX Series 6 Axis F/T Sensor for Robotics & General testing

Model	Description	Measurement Range(N/Nm)				Dimension (mm)			Weight (Kg)
		FX,FY	FZ	MX,MY	MZ	OD	Height	ID	
M3725A	6 AXIS LOADCELL D85MM F200N, CAN&RS232	200	400	50	50	88	20	13	0.54
M3705B	6 AXIS LOADCELL D90MM F100N	100	200	7	7	90	23	45	0.18
M3705C	6 AXIS LOADCELL D90MM F200N	200	400	14	14	90	23	45	0.18
M3715A	6 AXIS LOADCELL D90MM F400N	400	800	28	28	90	23	45	0.45
M3715B	6 AXIS LOADCELL D90MM F800N	800	1600	56	56	90	23	45	0.45
M3715C	6 AXIS LOADCELL D90MM F1600N	1600	3200	112	112	90	23	45	0.45
M3715CT1	6 AXIS LOADCELL D90MM F1600N DIGITAL OUTPUT	1600	3200	112	112	90	23	*	1.00
M3715D	6 AXIS LOADCELL D90MM F3200N	3200	6400	224	224	90	23	45	0.45
M3706B	6 AXIS LOADCELL D135MM F100N	100	200	10	10	135	25	80	0.39
M3706C	6 AXIS LOADCELL D135MM F200N	200	400	20	20	135	25	80	0.39
M3716A	6 AXIS LOADCELL D135MM F400N	400	800	40	40	135	25	80	1.00
M3716AT1	6 AXIS LOADCELL D135MM F400N DIGITAL OUTPUT	400	800	40	40	135	25	*	1.00
M3716B	6 AXIS LOADCELL D135MM F800N	800	1600	80	80	135	25	80	1.00
M3716C	6 AXIS LOADCELL D135MM F1600N	1600	3200	160	160	135	25	80	1.00
M3716D	6 AXIS LOADCELL D135MM F3200N	3200	6400	320	320	135	25	80	1.00



M33XX Series 6 axis loadcell for industrial application, 10X overload

M33XX series is structurally decoupled, designed for industrial application with 10 times overload capacity, IP65 protection, embedded low-noise amplifier, nonlinearity & hysteresis 1%, crosstalk 5%.

Model	Description	Measurement Range (N/Nm)				Dimension (mm)		Weight (Kg)
		FX,FY	FZ	MX,MY	MZ	OD	Height	
M3314A	6 AXIS LC D104MM F165N W/ OL STOPS&	165	495	15	15	104	40	1.25
M3314B	6 AXIS LC D104MM F330N W/ OL STOPS&	330	990	30	30	104	40	1.25
M3314C	6 AXIS LC D104MM F660N W/ OL STOPS&	660	1980	60	60	104	40	1.25
M3325B	6 AXIS LC D160MM F1250N W/ OL STOPS&	1250	3125	200	200	168	62	2.80
M3325C	6 AXIS LC D160MM F2500N W/ OL STOPS&	2500	6250	400	400	168	62	5.00



M43XX Series 6 Axis F/T Sensor for Industrial Application

M43XX series 6 axis force/torque sensor provides 3 to 10 times overload protection. IP65 protection, integrated with low-noise amplifiers for some models, nonlinearity & hysteresis 0.5%, crosstalk 2.5%.

Model	Description	Measurement Range(N/Nm)				Dimension (mm)			Weight (Kg)
		FX,FY	FZ	MX,MY	MZ	OD	Height	ID	
M4313A	6 AXIS LC D85MM F100N, CAN&RS23	100	200	8	8	85	26.5	*	0.23
M4313A1	6 AXIS LC D85MM F100N	100	200	8	8	85	26.5	*	0.23
M4313M1A	6 AXIS LC D85MM F50N, RS485&RS232	50	50	4	4	77	26.5	*	0.23
M4313M1B	6 AXIS LC D77MM F50N, TCP&RS232	50	50	4	4	77	26.5	*	0.23
M4313M2A	6 AXIS LC D85MM F100N, RS485&RS232	100	100	8	8	85	26.5	*	0.23
M4313M2B	6 AXIS LC D85MM F100N, TCP&RS232	100	100	8	8	85	26.5	*	0.23
M4313M3B	6 AXIS LC D95MM F160N, TCP&RS232	160	160	15	15	95	28.5	*	0.36
M4313M4A	6 AXIS LC D95MM F250N, RS485&RS232	250	250	24	24	95	28.5	*	0.36
M4313M4B	6 AXIS LC D95MM F250N, TCP&RS232	250	250	24	24	95	28.5	*	0.36
M4324A	6 AXIS LC D68MM F300N, EtherCAT	300	300	30	30	68	30	17	0.30
M4324A1	6 AXIS LC D68MM F300N	300	300	30	30	68	30	17	0.30
M4324B	6 AXIS LC D68MM F800N	800	800	90	90	68	28.2	17	0.36
M4324R	6 AXIS LC D90MM F1250N	1250	1250	250	250	90	25.7	35	0.78
M4325B	6 AXIS LC D91MM F200N, AMP	200	400	20	20	91	36	*	0.77
M4325K	6 AXIS LC D91MM F200N, AMP	200	400	20	20	91	31	32	0.56
M4325K1	6 AXIS LC D91MM F200N	200	400	20	20	91	31	32	0.56
M4325M	6 AXIS LC D91MM F400N, AMP	400	800	40	40	91	31	32	0.56
M4325N	6 AXIS LC D91MM F200N, EtherCAT	200	400	20	20	91	31	32	0.56
M4325N2	6 AXIS LC D91MM F100N, EtherCAT	100	200	10	10	91	31	25	0.58
M4325N4	6 AXIS LC D91MM F50N, EtherCAT	50	50	5	5	91	31	32	0.56
M4325N5	6 AXIS LC D91MM F200N, EtherCAT	200	400	20	20	91	31	*	0.70
M4325R	3 AXIS LC D100MM F4000N	3000	4000	NA	NA	100	30	*	1.30
M4325S	3 AXIS LC D100MM F2000N	2000	2000	NA	NA	100	30	*	1.30
M4336A	6 AXIS LC D91MM F130N, AMP	130	130	9	9	91	37.2	*	0.59
M4342R1	6 AXIS LC D160MM F10kN	10000	10000	1000	1000	160	50	*	5.90
M4342R2	6 AXIS LC D160MM F30kN	30000	30000	3000	3000	160	50	*	5.90
M4344A	6 AXIS LC D180MM F400N, AMP	400	400	50	50	180	37.2	85	1.60
M4344B	6 AXIS LC D180MM F800N, AMP	800	800	120	120	180	37.2	85	1.60
M4344C	6 AXIS LC D180MM F1600N, AMP	1600	1600	240	240	180	37.2	85	3.10
M4344D	6 AXIS LC D180MM F3200N, AMP	3200	3200	480	480	180	37.2	85	3.10
M4344R	6 AXIS LC D180MM F15KN	5000	15000	500	500	180	60	70	7.70
M4344R2	6 AXIS LC D180MM F30KN	8000	30000	800	800	180	60	70	7.70
M4344R3	6 AXIS LC D180MM F30KN	15000	30000	800	800	180	60	70	7.70
M4344R4	6 AXIS LC D180MM F5KN, AMP	5000	5000	500	500	180	60	70	7.70
M4344T2	6 AXIS ROBOT BASE LC D190MM F1600N	1600	1600	450	450	190	48	*	6.20
M4344T2C	6 AXIS ROBOT BASE LC D190MM, UDP&RS232	1600	1600	450	450	190	48	*	6.20
M4344T3	6 AXIS ROBOT BASE LC D190MM F1600N	1600	1600	450	450	190	48	*	6.20

M43XX Series 6 Axis F/T Sensor for Industrial Application

Model	Description	Measurement Range (N/Nm)				Dimension (mm)		Weight (Kg)
		FX,FY	FZ	MX,MY	MZ	OD	Height	
M4344T4	6 AXIS ROBOT BASE LC D190MM F1000N	1000	1000	250	250	190	48	6.20
M4347B	6 AXIS LC D280MM F4000N, AMP	4000	4000	800	800	280	51	9.90
M4347D	6 AXIS LC D280MM F15KN, AMP	15000	30000	6000	6000	280	51	9.90
M4347D1	6 AXIS LC D280MM F15KN, AMP	15000	30000	6000	6000	280	54	10.00
M4347D6	6 AXIS LC D280MM F6KN, AMP	6000	12000	2500	2500	280	51	9.90
M4347K	6 AXIS LC D280MM F6KN, AMP, DECOUPLED	6000	12000	2500	2500	280	51	9.90
M4347M	6 AXIS LC D280MM F15KN, AMP, DECOUPLED	15000	30000	6000	6000	280	51	9.90

M35XX Series 6 Axis F/T Sensor - Extra Thin

M35XX series is patented 6 axis F/T sensor with thickness of 9.2mm, thinnest commercially available. The sensors are matrix-decoupled, nonlinearity & hysteresis 1%, crosstalk 3%, overload 300%, IP60 protection.



Model	Description	Measuring Range(N/Nm)				Dimension (mm)			Weight (Kg)
		FX,FY	FZ	MX,MY	MZ	OD	Height	ID	
M3552B	EXTRA THIN 6 AXIS LC D30MM F150N	150	250	2.25	2.25	30	9.2	5	0.01
M3552C	EXTRA THIN 6 AXIS LC D30MM F300N	300	500	4.50	4.50	30	9.2	5	0.03
M3552D	EXTRA THIN 6 AXIS LC D30MM F600N	600	1000	9.00	9.00	30	9.2	5	0.03
M3553B	EXTRA THIN 6 AXIS LC D45MM F150N	150	250	3.50	3.50	45	9.2	9	0.03
M3553C	EXTRA THIN 6 AXIS LC D45MM F300N	300	500	7.00	7.00	45	9.2	10	0.06
M3553D	EXTRA THIN 6 AXIS LC D45MM F600N	600	1000	13.50	13.50	45	9.2	10	0.06
M3553E	EXTRA THIN 6 AXIS LC D45MM F1200N	1200	2000	27.00	27.00	45	9.2	10	0.06
M3554C	EXTRA THIN 6 AXIS LC D60MM F300N	300	500	10.00	10.00	60	9.2	21	0.11
M3554D	EXTRA THIN 6 AXIS LC D60MM F600N	600	1000	20.00	20.00	60	9.2	21	0.11
M3554E	EXTRA THIN 6 AXIS LC D60MM F1200N	1200	2000	40.00	40.00	60	9.2	21	0.11
M3555D	EXTRA THIN 6 AXIS LC D90MM F600N	600	1000	40.00	40.00	90	9.2	45	0.26
M3564C	EXTRA THIN 6 AXIS LC D60MM F2000N	1200	1200	40.00	30.00	60	10	7	0.06
M3564F	EXTRA THIN 6 AXIS LC D65MM F2500N	2500	5000	200.00	100.00	65	9.2	10	0.19
M3564G-2X	EXTRA THIN 2 AXIS LC D65MM F100N	NA	1000	100.00	NA	65	10	10	0.19
M3535E	6 AXIS LC EXTRA THIN D58MM F200N	200	300	22	30	58	7.5	*	0.11
M3535E1	6 AXIS LC EXTRA THIN D70MM F200N	200	300	22	30	70	9.5	16	0.19

M38XX Series 6 Axis F/T Sensor for Low Capacity & High Accuracy

M38XX series 6 axis force/torque sensors are matrix-decoupled with low capacity & high accuracy, nonlinearity and hysteresis less than 0.5%, crosstalk less than 2%, overload protection from 600% to 1000%. Suited for robot applications in high-precision assembling and wind tunnel testing. Integrated amplifiers or DAQ available for models OD 75mm or larger. IP60 protection.

Model	Description	Measurement Range (N/Nm)				Dimension (mm)		Weight (Kg)	Voltage
		FX,FY	FZ	MX,MY	MZ	OD	Height		
M3813A	6 AXIS LOADCELL D45MM F40N	40	40	1.5	1.5	45	31	0.09	
M3813B	6 AXIS LOADCELL D45MM F70N	70	70	3	3	45	31	0.09	
M3813C	6 AXIS LOADCELL D45MM F130N	130	130	6	6	45	31	0.09	
M3813D	6 AXIS LOADCELL D45MM F260N	260	260	12	12	45	31	0.09	
M3813E	6 AXIS LOADCELL D45MM F520N	520	520	24	24	45	31	0.20	
M3815A	6 AXIS LOADCELL D75MM F40N	40	40	2.5	2.5	75	35	0.41	±15V
M3815A1	6 AXIS LOADCELL D75MM F40N	40	40	3	3	75	35	0.41	+24V
M3815B	6 AXIS LOADCELL D75MM F70N	70	70	5	5	75	35	0.41	±15V
M3815B1	6 AXIS LOADCELL D75MM F70N	70	70	5	5	75	35	0.41	+24V
M3815C	6 AXIS LOADCELL D75MM F130N	130	130	10	10	75	35	0.41	±15V
M3815C1	6 AXIS LOADCELL D75MM F130N	130	130	10	10	75	35	0.41	+24V
M3815D	6 AXIS LOADCELL D75MM F260N	260	260	20	20	75	35	0.41	±15V
M3815D1	6 AXIS LOADCELL D75MM F260N	260	260	20	20	75	35	0.41	+24V
M3816A	6 AXIS LOADCELL D100MM F40N	40	40	3.5	3.5	100	35	0.69	
M3816B	6 AXIS LOADCELL D100MM F70N	70	70	7	7	100	35	0.69	
M3816C	6 AXIS LOADCELL D100MM F130N	130	130	14	14	100	35	0.69	
M3816D	6 AXIS LOADCELL D100MM F260N	260	260	28	28	100	35	0.69	
M3816E	6 AXIS LOADCELL D100MM F520N	520	520	56	56	100	35	0.69	
M3816AH	6 AXIS LOADCELL D100MM F40N	40	40	3.5	3.5	100	35	0.69	
M3816BH	6 AXIS LOADCELL D100MM F70N	70	70	7	7	100	35	0.69	
M3816CH	6 AXIS LOADCELL D100MM F130N	130	130	14	14	100	35	0.69	
M3816DH	6 AXIS LOADCELL D100MM F260N	260	260	28	28	100	35	0.69	
M3816EH	6 AXIS LOADCELL D100MM F520N	520	520	56	56	100	35	0.69	
M3816FH	6 AXIS LOADCELL D100MM F1040N	1040	1040	112	112	100	35	1.20	
M3817EH	6 AXIS LOADCELL D150MM F520N	520	520	84	84	150	35	1.40	
M3818BH1	6 AXIS LOADCELL D200MM F100N	100	300	40	40	200	44	3.30	
M3818FH1	6 AXIS LOADCELL D200MM F500N	500	1200	250	200	200	44	3.30	



M39XX Series 6 Axis Loadcell - Large Capacity

Structurally decoupled type large-range six-axis force sensor. The outer diameter range from 60mm to 135mm, and the maximum range is 291,600N. Maximum overload 200%. IP60 protection. The letter "P" at the end of the model number indicates IP68 protection level (e.g. M3965P). The M39XX series have nonlinearity and hysteresis less than 1%F.S., and crosstalk less than 5%F.S.

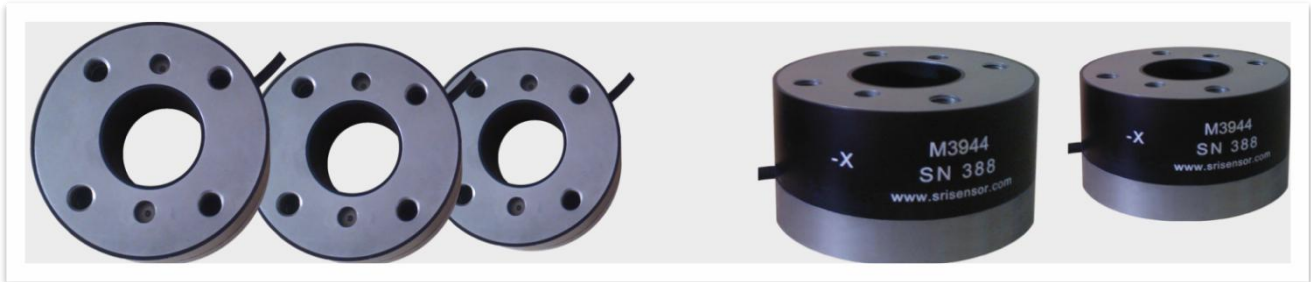

Model	Description	Measurement Range(N/Nm)				Dimension (mm)			Weight (Kg)
		FX,FY	FZ	MX,MY	MZ	OD	Height	ID	
M3923	6 AXIS LOADCELL D60MM F2700N	2700	5400	120	96	60	40	15	0.18
M3924	6 AXIS LOADCELL D90MM F2700N	2700	5400	180	144	90	40	35	0.37
M3925A	6 AXIS LOADCELL D135MM F2700N	2700	5400	270	216	135	40	70	0.72
M3933	6 AXIS LOADCELL D60MM F5400N	5400	10800	240	192	60	40	15	0.48
M3933B2	6 AXIS LOADCELL D60MM F5400N,DIGITAL	5400	10800	240	192	60	40	*	0.51
M3934	6 AXIS LOADCELL D90MM F5400N	5400	10800	360	288	90	40	35	0.99
M3935	6 AXIS LOADCELL D135MM F5400N	5400	10800	540	432	135	40	70	1.95
M3935M	6 AXIS LOADCELL D135MM F5400N, CENTER	5400	10800	540	432	135	40	70	1.95
M3935Z1	6 AXIS LOADCELL D135MM F5400N, CONNECTOR	5400	10800	540	432	135	40	70	1.95
M3943	6 AXIS LOADCELL D60MM F16200N	16200	32400	660	530	60	50	15	0.62
M3943F-3X	3 AXIS LOADCELL D60MM F30000N	30000	50000	NA	NA	60	35	*	0.42
M3944	6 AXIS LOADCELL D90MM F16200N	16200	32400	1000	800	90	50	35	1.30
M3945	6 AXIS LOADCELL D135MM F16200N	16200	32400	1500	1200	135	50	57	2.90
M3945-3X	3 AXIS LOADCELL D135MM F16200N	16200	32400	NA	NA	135	50	57	2.90
M3954	6 AXIS LOADCELL D90MM F48600N	48600	97200	3000	2400	90	75	33	4.70
M3955	6 AXIS LOADCELL D135MM F48600N	48600	97200	4500	3600	135	75	47	4.70
M3955B1	3 AXIS LOADCELL D135MM F50kN	50k	100k	NA	NA	135	75	47	4.70
M3955B2	3 AXIS LOADCELL D135MM F50kN	50k	150k	NA	NA	135	75	47	4.70
M3965	6 AXIS LOADCELL D135MM F145.8kN	145.8k	291.6k	13.5k	10.8k	135	120	47	7.40
M3965B	6 AXIS LOADCELL D135MM F100kN	100k	250k	20k	15k	135	120	47	7.40
M3965C	3 AXIS LOADCELL D135MM F150kN	150k	400k	NA	NA	135	120	47	7.40
M3965D	3 AXIS LOADCELL D135MM F200kN	200k	600k	NA	NA	135	120	47	7.40
M3965E	6 AXIS LOADCELL D135MM F200kN	200k	600k	20k	15k	135	120	47	7.40
M3966A	6 AXIS LOADCELL D185MM F200kN	200k	400k	40k	20k	185	135	50	16.80

M3612X Series 6 Axis Force Platform

Model	Description	Measurement Range(N/Nm)				Dimension (mm)			Weight (Kg)
		FX,FY	FZ	MX,MY	MZ	L	W	H	
M3612A	6 AXIS FORCE PLATE 400 X 600MM	1250	2500	500	500	400	600	100	36.00
M3612B	6 AXIS FORCE PLATE 400 X 600MM	2500	5000	1000	1000	400	600	100	36.00
M3612C	6 AXIS FORCE PLATE 400 X 600MM	5000	10000	2000	2000	400	600	100	36.00
M3612G	6 AXIS FORCE PLATE 400 X 600MM	2500	5000	800	600	400	600	134	46.00
M3612M	6 AXIS FORCE PLATE 400 X 600MM	10000	10000	6000	6000	400	600	134	49.00
M3613B	6 AXIS FORCE PLATE 400 X 600MM + WINDOW	2500	5000	1000	1000	400	600	120	40.10
M3612BT	6 AXIS FORCE PLATE 400 X 600MM, COUPLED	2500	5000	1000	1000	400	600	100	36.00
M3614BT	6 AXIS FORCE PLATE 450 X 450MM, COUPLED	2500	5000	800	600	450	450	100	30.00



M21XX Series & M36XX Series Uniaxial force sensor, specialty force sensor

SRI manufactures special uniaxial and multiaxial force transducers. Although some models have a small range, they have a strong anti-overload capability, making them more secure to use in industrial sites. Many models are customized by ABB and can be directly equipped with ABB robots.

Model	Description	Measurement Range(N/Nm)				Dimension (mm)			Weight (Kg)
		FX,FY	FZ	MX,MY	MZ	OD	Height	ID	
M2106A	UNIAXIAL TOUCH SENSOR W/ OL STOPS	NA	5	NA	NA	14	8.5	47	0.01
M2106B	UNIAXIAL TOUCH SENSOR W/ OL STOPS	NA	10	NA	NA	14	8.5	47	0.01
M2108C1	SINGLE AXIS LOADCELL 100N W/ OL STOPS	NA	200	NA	NA	89	33	*	0.24
M2108D	SINGLE AXIS LOADCELL 100N W/ OL STOPS	NA	100	NA	NA	89	33	*	0.24
M2108M	SINGLE AXIS LOADCELL 500N W/ OL STOPS	NA	500	NA	NA	89	33	*	0.41
M2109B	SINGLE AXIS LOADCELL 2000N	NA	2000	NA	NA	50	30	*	0.26
M2109E	SINGLE AXIS LOADCELL 100N	NA	100	NA	NA	64	20	*	0.11
M2112B	UNIAXIAL SENSOR W/ OL STOPS FOR RB120	NA	200	NA	NA	89	33	27	0.24
M2125	UNIAXIAL SENSOR, SMALL, HIGH CAPACITY	NA	4500	NA	NA	21.6	8.9	6.6	0.15
M3619A	UNIAXIAL LOADCELL 12kN	NA	12k	NA	NA	25	55	*	0.10
M3619A1	UNIAXIAL LOADCELL 20kN	NA	20k	NA	NA	25	66	*	0.12
M3619B	UNIAXIAL LOADCELL 40kN	NA	40k	NA	NA	50	100	*	0.58

M21XX Series & M36XX Series Uniaxial Force Sensor, Specialty Force Sensor

Model	Description	Measurement Range(N/Nm)				Dimension (mm)			Weight (Kg)
		FX,FY	FZ	MX,M Y	MZ	L	W	H	
M3619B1	UNIAXIAL LOADCELL 20kN	NA	20k	NA	NA	50	70	*	0.50
M3619C	UNIAXIAL LOADCELL 80kN	NA	80k	NA	NA	50	100	*	0.58
M3619D	UNIAXIAL LOADCELL 100kN	NA	100k	NA	NA	50	100	*	0.58
M3619M	UNIAXIAL LOADCELL 5000N	NA	5000	NA	NA	30	32	*	0.10
M3621B	UNIAXIAL LOADCELL 10kN	NA	10k	NA	NA	15	11	*	0.10
M3621P	UNIAXIAL LOADCELL 5000N	NA	5000	NA	NA	45	21	*	0.17
M3623C	UNIAXIAL LOADCELL 70kN	NA	70	NA	NA	282	50	200	5.70
M3624A1	UNIAXIAL LOADCELL 13kN	NA	13k	NA	NA	25	43	*	0.07
M3624BP	UNIAXIAL LOADCELL 13kN	NA	13k	NA	NA	24	100	*	0.24
M3626AP	UNIAXIAL LOADCELL 14kN	NA	14k	NA	NA	36	29	*	0.15
M3626BP	UNIAXIAL LOADCELL 50kN	NA	50k	NA	NA	60	39	*	0.49
M3626CP	UNIAXIAL LOADCELL 17kN	NA	17k	NA	NA	36	29	*	0.15
M3627A	THREE AXIS FOOT LOADCELL 84×93mm F8kN	8000	8000	NA	NA	93	79.5	84	1.00
M3627FP	UNIAXIAL FOOT LOADCELL 45kN	NA	45k	NA	NA	102	70	66	0.35
M3628KP	6 AXIS LOADCELL D180MM F12N	3k	12k	1k	1k	180	82	75.8	13.70
M3628M1	UNIAXIAL LOADCELL 1000N	NA	1000	NA	NA	38	30.5	*	0.24
M4312B1	6 AXIS SQUARE LC 10×40×47mm THICK F80N	80	80	1.2	1.2	47	40	10	0.04
M4312G	6 AXIS SQUARE LC 30×30×22mm F20N	20	40	1.5	1	30	30	22	0.05
M4312H	6 AXIS LC D36MM F500N	500	500	9	9	36	21	*	0.08
M3635A	6 AXIS LOADCELL D63MM F100N	100	100	5	5	63	22	*	0.18
M3635G	6 AXIS LOADCELL D63MM F1600N	1600	3200	56	56	63	14	*	0.25
M3636A	6 AXIS LC FINGER TIP F100N	100	200	1	1	15.4	35	*	0.01
M3615B	3 AXIS FORCE D130MM F45kN	45k	60k	NA	NA	130	60	*	3.40
M3615C	3 AXIS FORCE D130MM F20kN	20k	50k	NA	NA	130	52	*	2.50
M3616C	6 AXIS FORCE D90MM F2700	2700	4000	180	144	90	36	40	0.32
M3604D1	6 AXIS SHOE CELL COUPLED 1500N	1200	2400	40	30	120	32	55	0.49
M4341A	6 AXIS SQUARE LC 60×60×15mm F9N	9	10	0.3	0.15	60	15	60	0.10
M4341B	6 AXIS SQUARE LC 60×60×15mm F13N	13	20	1.2	0.6	60	15	60	0.10
M4341C	6 AXIS SQUARE LC 60×60×15mm F25N	25	50	2.5	2.5	60	15	60	0.10

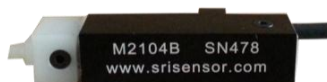



Torque Sensor

SRI torque sensors are specially designed for robot joints and can be widely used in collaborative robots and medical robots. The sensor thickness is as thin as 7mm, the diameter is 20 to 200mm and the torque capacity is 10Nm to 800Nm.

A built-in amplifier is included. The DC voltage input is 5V, and the output is 0–5V. The SRI torque sensor features a light and thin structure, simple installation, strong bending resistance, small crosstalk between axes, and its stiffness is more than 4 times that of harmonic gear.

M22XX Series Robot Torque Sensor

The M2210XX series is a single-axis torque sensor specifically designed for torque measurement of robot joints. It is widely used in collaborative robots and medical robots. SRI's torque sensors are as thin as 7mm and 53 to 200mm in diameter, with torque ranges from 10Nm to 800Nm. The sensor has built-in amplifier, 5V DC input, 0-5V output. Digital output at request.

Model	Description	Measurement Range	Dimension (mm)			Weight (Kg)
		Nm	OD	Height	ID	
M2210A	TORQUE SENSOR D53MM T50NM	50	53	7	13	0.09
M2210A2	TORQUE SENSOR D53MM T100Nm	100	53	7	13	0.09
M2210A3	TORQUE SENSOR D78MM T50Nm	50	78	7	13	0.20
M2210A4	TORQUE SENSOR D53MM 50Nm	50	53	7	13	0.09
M2210A9	TORQUE SENSOR D53MM 50Nm	50	53	7	13	0.09
M2210B	TORQUE SENSOR D100MM T250Nm	250	100	8	27	0.37
M2210B1	TORQUE SENSOR D100MM T250Nm	250	100	8	27	0.37
M2210B2	TORQUE SENSOR D100MM T250Nm	250	100	8	27	0.37
M2210B3	TORQUE SENSOR D100MM T250Nm	250	100	8	27	0.37
M2210B4	TORQUE SENSOR D100MM T250Nm	250	100	8	27	0.37
M2210B5	TORQUE SENSOR D100MM T250Nm HIGH BENDING	250	100	26.2	27	0.96
M2210B6	TORQUE SENSOR D100MM T250Nm	250	100	8	27	0.37
M2210B7	TORQUE SENSOR D100MM T250Nm	250	100	8	27	0.37
M2210C	TORQUE SENSOR D80MM T100Nm	100	80	7	20	0.18
M2210C1	TORQUE SENSOR D80MM T100Nm	100	80	7	20	0.18
M2210C2	TORQUE SENSOR D80MM T150Nm	150	80	7	19	0.18
M2210C3	TORQUE SENSOR D80MM T150Nm	150	80	7	19	0.18
M2210C4	TORQUE SENSOR D80MM T100Nm	100	80	7	20	0.18
M2210C5	TORQUE SENSOR D80MM T100Nm	100	80	7	20	0.20
M2210C6	TORQUE SENSOR D111MM T100Nm	100	111	7	20	0.30
M2210C7	TORQUE SENSOR D82MM T150Nm	150	82	7	20	0.18
M2210C8	TORQUE SENSOR D82MM T150Nm	150	82	7	15	0.21
M2210C9	TORQUE SENSOR D80MM T100Nm	100	80	7	20	0.18
M2210C10	TORQUE SENSOR D108MM T250Nm	250	108	8	32	0.38
M2210C11	TORQUE SENSOR D70MM T70Nm	70	70	7	13	0.15
M2210C12	TORQUE SENSOR D108MM T250Nm	250	108	8	22	0.45
M2210C13	TORQUE SENSOR D70MM T50Nm	50	70	7	16	0.16
M2210D	TORQUE SENSOR D100MM T300NM	300	100	8	14	0.38
M2210E	TORQUE SENSOR D53MM T60Nm	60	53	7	13	0.09
M2210E1	TORQUE SENSOR D53MM T60Nm	60	53	8	10	0.09
M2210E2	TORQUE SENSOR D53MM T100Nm	100	53	8	*	0.08
M2210F	TORQUE SENSOR D53MM T30Nm	30	53	7	13	0.09
M2210F1	TORQUE SENSOR D59MM T30Nm	30	59	7	13	0.10
M2210F2	TORQUE SENSOR D53MM T30Nm	30	53	7	13	0.09
M2210G	TORQUE SENSOR D84MM T150Nm OIL SEAL	150	84	12.5	17	0.32

M22XX Series Robot Torque Sensor

Model	Description	Measurement Range	Dimension (mm)			Weight (Kg)
		Nm	OD	Height	ID	
M2210G1	TORQUE SENSOR D84MM T150Nm OIL SEAL	150	84	12.5	17	0.32
M2210G2	TORQUE SENSOR D84MM T150Nm OIL SEAL	150	84	12.5	17	0.32
M2210G3	TORQUE SENSOR D80MM T180Nm OIL SEAL	180	80	12.5	20	0.32
M2210G5	TORQUE SENSOR D84MM T150Nm OIL SEAL, HIGH BENDING	150	84	24.9	17	0.69
M2210G6	TORQUE SENSOR D84MM T150Nm OIL SEAL	150	84	12.5	17	0.32
M2210G7A	TORQUE SENSOR D84MM T180Nm OIL SEAL	180	84	12.5	20	0.30
M2210H	TORQUE SENSOR D53MM T50Nm HIGH BENDING	50	53	7	13	0.09
M2210H5	TORQUE SENSOR D53MM T50Nm	50	53	19	13	0.19
M2210L	TORQUE SENSOR D53MM T60Nm	60	53	7	13	0.09
M2210M	TORQUE SENSOR D53MM T20Nm	20	53	7	13	0.09
M2210M1	TORQUE SENSOR D68MM T20Nm	20	68	7	13	0.15
M2210M2	TORQUE SENSOR D78MM T20Nm	20	78	6	13	0.20
M2210M6	TORQUE SENSOR D53MM T20Nm	20	53	7	13	0.09
M2210N	TORQUE SENSOR D62MM T50Nm	50	62	7	12	0.14
M2210N1	TORQUE SENSOR D62MM T50Nm	50	62	7	12	0.14
M2210N2	TORQUE SENSOR D62MM T150Nm	150	62	7	12	0.14
M2210N3	TORQUE SENSOR D62MM T150Nm	150	62	7	12	0.14
M2210N4	TORQUE SENSOR D62MM T50Nm	50	62	7	12	0.14
M2210P	TORQUE SENSOR D146MM T250Nm	250	146	34	16	0.38
M2210R	TORQUE SENSOR D104MM T150Nm	150	104	25	16	0.20
M2210S	TORQUE SENSOR D41MM T40Nm	40	41	7	11	0.05
M2210T	TORQUE SENSOR D103MM T330Nm	330	103	6	26	0.14
M2210T1	TORQUE SENSOR D103MM T230Nm	230	103	6	24	0.14
M2210T2	TORQUE SENSOR D103MM T330Nm	330	103	6	24	0.14
M2210U	TORQUE SENSOR D103MM T150Nm	150	103	5	19	0.14
M2210U1	TORQUE SENSOR D103MM T123NM	123	103	5	18	0.14
M2210V	TORQUE SENSOR D101MM T70Nm	70	101	6	16.4	0.10
M2210V1	TORQUE SENSOR D101MM T70NM	70	101	6	16	0.10
M2210W	TORQUE SENSOR D66MM T50Nm	50	66	7	19	0.12
M2210W1	TORQUE SENSOR D66MM T50Nm	50	66	7	19	0.12
M2210Y	TORQUE SENSOR D61MM T100Nm	100	61	8.5	13.5	0.18
M2211A	TORQUE SENSOR D82MM T150Nm HIGH BENDING	150	82	22	26	0.26
M2211B	TORQUE SENSOR D110MM T250Nm HIGH BENDING	250	110	22	37	0.39
M2211C	TORQUE SENSOR D58.5MM T50Nm For LHD-17	50	58.5	8	*	0.04
M2211D	TORQUE SENSOR D53.5MM T50Nm for LHD-14	50	53.5	8	*	0.12
M2211D1	TORQUE SENSOR D53.5MM T50Nm for LHD-14	50	53.5	8	*	0.04
M2211G	TORQUE SENSOR D45MM T10Nm	10	45	6	*	0.03

M22XX Series Robot Torque Sensor

Model	Description	Measurement Range	Dimension (mm)			Weight (Kg)
		Nm	OD	Height	ID	
M2211G1	TORQUE SENSOR D45MM T10Nm	10	45	6	*	0.03
M2211H	TORQUE SENSOR D63MM T40Nm for LHS-17, OIL SEAL	40	63	11	*	0.15
M2211J	TORQUE SENSOR D118MM T250Nm	250	118	11	44	0.69
M2211K	TORQUE SENSOR D72MM T50Nm OIL SEAL	50	72	12	*	0.22
M2211M	TORQUE SENSOR D50MM T40Nm DUAL CHANNEL	40	50	8	11	0.07
M2211M1	TORQUE SENSOR D50MM T40Nm	40	50	8	11	0.07
M2211M2	TORQUE SENSOR D50MM T40Nm	40	50	8	11	0.07
M2211N	TORQUE SENSOR D60MM T80Nm DUAL CHANNEL	80	60	8	10	0.10
M2211N2	TORQUE SENSOR D60MM T80Nm	80	60	8	10	0.10
M2211P	TORQUE SENSOR D70MM T140Nm DUAL CHANNEL	140	70	10.2	16	0.19
M2211P1	TORQUE SENSOR D70MM T140Nm	140	70	10.2	16	0.19
M2211Q	TORQUE SENSOR D85MM T250Nm DUAL CHANNEL	250	85	10.2	20	0.28
M2211Q1	TORQUE SENSOR D85MM T250Nm	250	85	10.2	20	0.28
M2211Q2	TORQUE SENSOR D85MM T250Nm	250	85	10.2	20	0.28
M2211Q3	TORQUE SENSOR D85MM T250Nm	250	85	10.2	20	0.28
M2211T1	TORQUE SENSOR D86MM T200Nm	200	86	8	*	0.30
M2211T2	TORQUE SENSOR D86MM T100Nm	100	86	8	*	0.30
M2211V1	TORQUE SENSOR D71MM T100Nm	100	71	8	19	0.15
M2211V2	TORQUE SENSOR D71MM T50Nm	50	71	8	19	0.14
M2211V6	TORQUE SENSOR D69MM T100Nm	100	69	8.5	14	0.15
M2211V7	TORQUE SENSOR D71MM T100Nm	100	71	8	19	0.15
M2211V8	TORQUE SENSOR D71MM T100Nm	100	71	8	19	0.15
M2211W1	TORQUE SENSOR D69MM T30Nm	30	69	10	14	0.20
M2211Z1	TORQUE SENSOR D61MM T150Nm	150	61	8	*	0.15
M2211Z2	TORQUE SENSOR D85MM T300Nm	300	85	8	35	0.38
M2211Z2	TORQUE SENSOR D85MM T300Nm	300	85	8	35	0.38
M2212A	TORQUE SENSOR D95MM T150Nm	150	95	7	20	0.18
M2212A1	TORQUE SENSOR D95MM T150Nm	150	95	7	20	0.18
M2212B1	TORQUE SENSOR D60MM T25Nm	25	60	24.5	9	0.20
M2212B2	TORQUE SENSOR D80MM T70Nm	70	80	28.4	14	0.37
M2212B3	TORQUE SENSOR D92MM T140Nm	140	92	28.5	28	0.60
M2212C	TORQUE SENSOR D88MM T250Nm	250	88	8	26	0.30
M2212D	TORQUE SENSOR D118MM T150Nm	150	118	12.4	22	0.57
M2212G1	TORQUE SENSOR D96MM T400Nm	400	96	10	20	0.38
M2212G2	TORQUE SENSOR D86MM T200Nm	200	86	10	24	0.30
M2212G3	TORQUE SENSOR D64MM T80Nm	80	64	13	13	0.15
M2212K1	TORQUE SENSOR D75MM T40Nm	40	75	17	20	0.07

M22XX Series Robot Torque Sensor



Model	Description	Measurement Range	Dimension (mm)			Weight (Kg)
		Nm	OD	Height	ID	
M2212K2	TORQUE SENSOR D105MM T160Nm	160	105	22.9	26	0.40
M2212K3	TORQUE SENSOR D130MM T340Nm	340	130	24.9	32	0.76
M2212L	TORQUE SENSOR D67MM T250Nm	250	67	16	*	0.27
M2212M	TORQUE SENSOR D145MM T800Nm	800	145	8	30	0.76
M2212N1	TORQUE SENSOR D53MM T50Nm	50	53	12	9	0.12
M2212N2	TORQUE SENSOR D63.5MM T80Nm	80	63.5	16	10	0.18
M2212P	TORQUE SENSOR D80MM T100Nm	100	80	7	20	0.18
M2212P1	TORQUE SENSOR D46MM T20Nm For HD CSG-14	20	46	5.2	*	0.06
M2212P2	TORQUE SENSOR D46MM T40Nm For HD CSG-14	40	46	5.2	*	0.06
M2212P3	TORQUE SENSOR D55MM T80Nm For HD CSG-17	80	55	5.2	*	0.08
M2212Q	TORQUE SENSOR D60MM T100Nm	100	60	7	13	0.10
M2212R1	TORQUE SENSOR D120MM T200Nm	200	120	12	30	0.67
M2212R2	TORQUE SENSOR D75MM T50Nm	50	75	14	20	0.26
M2212R3	TORQUE SENSOR D79MM T20Nm	20	79	8	18	0.19
M2212S1	TORQUE SENSOR D92MM T140Nm	140	92	10	29	0.45
M2212S2	TORQUE SENSOR D78MM T70Nm	70	78	10	15	0.33
M2212S3	TORQUE SENSOR D60MM T25Nm	25	60	9	8	0.14
M2212S4	TORQUE SENSOR D90MM T40Nm	40	90	7	45	0.22
M2212S5	TORQUE SENSOR D84MM T70Nm	70	84	7	46	0.19
M2212S6	TORQUE SENSOR D95MM T140Nm	140	95	8	34	0.36
M2212S7	TORQUE SENSOR D115MM T300Nm	300	115	8	48	0.52
M2212U1	TORQUE SENSOR D88MM T150Nm	150	88	8.5	15.2	0.31
M2212U2	TORQUE SENSOR D98MM T250Nm	250	98	8	27	0.31
M2212U3	TORQUE SENSOR D64MM T50Nm	50	64	9	13	0.16

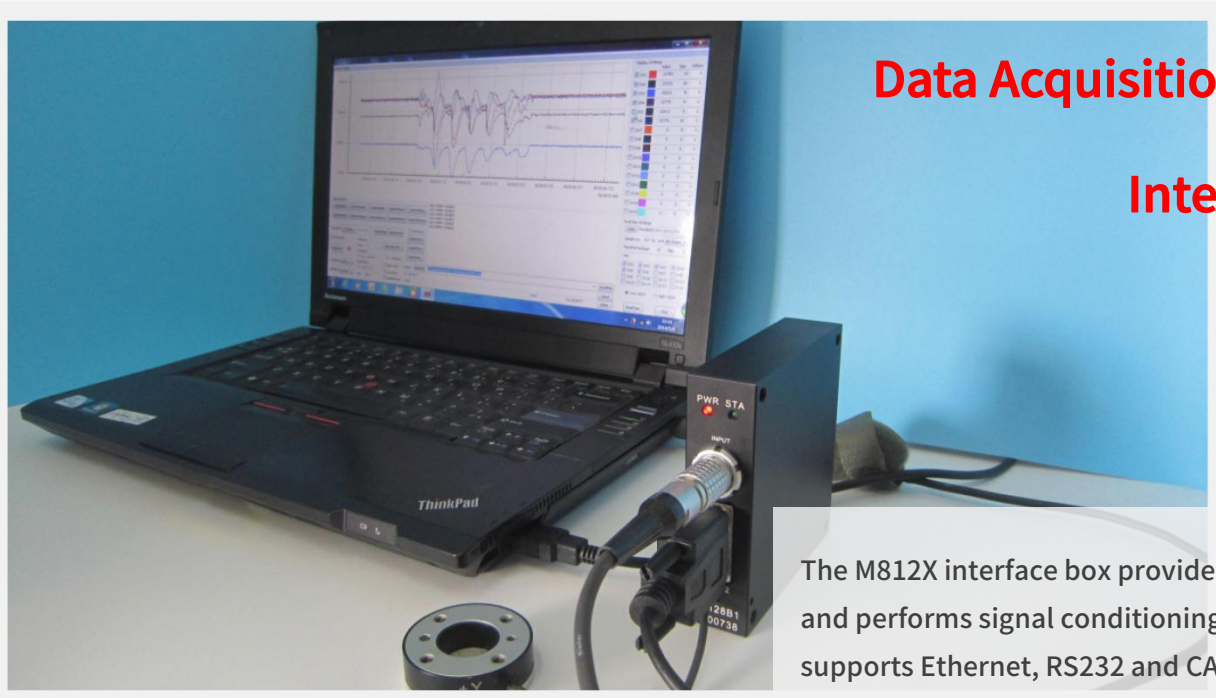

Data Acquisition System

Interface box

M812X

The M812X interface box provides excitation for the sensor and performs signal conditioning and acquisition. M8128 supports Ethernet, RS232 and CAN bus communication; M8126 supports EtherCAT and RS232; M8124 supports Profinet and RS232. Its communication commands are completely open, and data can be queried through simple AT commands. M812X adopts low noise instrumentation amplifier and A/D conversion chip with 24-bit resolution, the system resolution can reach 1/5000~1/40000FS, and the sampling rate can reach 2KHZ. The sensor is connected to the M812X via a 19-pin LEMO connector (LEMO FGG.2B.319.CLAD52Z).

Specifications:

Analog

- 6 channel analog input
- Programmable gain
- Programmable adjustment of zero offset
- Low noise instrumentation amplifier

Digital

- M8128: Ethernet TCP/IP, RS232, CAN
- M8126: EtherCAT, RS232
- 24-bit A/D, Sampling rate up to 2KHZ
- Resolution 1/5000~1/40000FS

Front Panel

- Sensor connector: LEMO FGG.2B.319.CLAD52Z
- Communication connector: Standard DB-9(including Ethernet, RS232, CAN BUS)
- Power: DC 12~36V, 200mA. 2m cable (diameter 3.5mm)
- Indicator lights: Power and status

Software

- iDAS RD: Debugging software, to display curve in real-time and to send commands to the interface box M812X
- Sample code: C++ source code, for RS232 or TCP/IP communication with M8128



OEM Data Acquisition Circuit Board

The OEM version of the data acquisition card is particularly suitable for applications with limited space and high integration requirements.

SRI offers OEM data acquisition cards with a variety of interfaces that provide sensor excitation, signal conditioning and acquisition.

The communication interface includes EtherCAT, RS232 and CAN bus, and its communication commands are completely open, and data can be queried through simple AT commands.

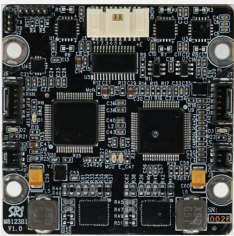
The use of low-noise instrumentation amplifiers and 24-bit A/D conversion chips makes the system resolution up to 1/5000-1/40000FS, and the sampling rate up to 2KHZ.

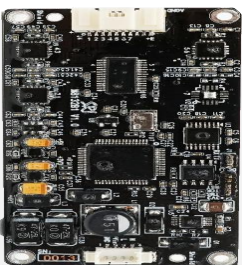
Model & Illustration	Electrical Interface	Dimensions & Software
 <p>M8123B2</p>	<ul style="list-style-type: none"> - 6-channel analog signal input - low-noise instrumentation amplification - Power supply DC24V, max.250mA - EtherCAT (dual channel, can be cascaded), RS232, CAN communication - 24-bit A/D conversion, the highest sampling rate is 2KHZ - Resolution 1/5000~1/40000FS 	<ul style="list-style-type: none"> - Dimension: Outer dimension 54mm; Thickness 13.3mm - iDAS RD: Debug software, display real-time sampling curve - EtherCAT device description file*.xml
 <p>M8123B1</p>	<ul style="list-style-type: none"> - 6-channel analog signal input - low-noise instrumentation amplification - Power supply DC24V, max.250mA - EtherCAT (dual channel, can be cascaded), RS232 - 24-bit A/D conversion, the highest sampling rate is 2KHZ - Resolution 1/5000~1/10000FS 	<ul style="list-style-type: none"> - Dimension: 50(l)*50(w)*15(h)mm - iDAS RD: Debug software, display real-time sampling curve - EtherCAT device description file*.xml
 <p>M8123D</p>	<ul style="list-style-type: none"> - 6-channel analog signal input - low-noise instrumentation amplification - Power supply DC24V, max.250mA - EtherCAT (dual channel, can be cascaded), RS232 - 24-bit A/D conversion, the highest sampling rate is 2KHZ - Resolution 1/5000~1/10000FS 	<ul style="list-style-type: none"> - Dimension: 30(l)*40(w)*11(h)mm - iDAS RD: Debug software, display real-time sampling curve - EtherCAT device description file*.xml
 <p>M8132B1</p>	<ul style="list-style-type: none"> - 6-channel analog signal input - low-noise instrumentation amplification - Power supply DC24V, max.250mA - RS232, CAN communication - 24-bit A/D conversion, the highest sampling rate is 2KHZ - Resolution 1/5000~1/40000FS 	<ul style="list-style-type: none"> - Dimension: 74.5(l)*35(w)*11(h)mm - iDAS RD: Debug software, display real-time sampling curve

Signal Amplifier

The M8301 and M8302 are amplifiers dedicated to SRI force transducers. The overall size is 56*60*23mm. The input and output of M8301 all use HIROSE connectors, and the M8302 uses cable for direct input and output. The amplifier is powered by DC24V and has various output forms, including single-ended 0-10V, single-ended -5V to +5V, fully differential +/-5V, fully differential +/-10V. Specify output forms when ordering.



Model	Differential Signal	Single-ended Signal	Connector
M8301A	$\pm 10V$ (common mode 0)	N/A	HIROSE
M8301B	$\pm 5V$ (common mode 0)	N/A	HIROSE
M8301C	N/A	+Signal $\pm 5V$, -Signal 0V	HIROSE
M8301F	N/A	+Signal 0~10V, -Signal 5V	HIROSE
M8301G	N/A	+Signal 0~5V, -Signal 2.5V	HIROSE
M8301H	N/A	+Signal $\pm 10V$, -Signal 0V	HIROSE
M8302A	$\pm 10V$ (common mode 0)	N/A	Open Ended
M8302C	N/A	+Signal 0~5V, -Signal 2.5V	Open Ended
M8302D	$\pm 5V$ (common mode 0)	N/A	Open Ended
M8302E	N/A	+Signal $\pm 5V$, -Signal 0V	Open Ended
M8302H	$\pm 1.5V$ (common mode 0)	N/A	Open Ended

IGR

Intelligent Grinder Independent force control system

iGrinder® is an independent force-controlled grinding system and does not rely on robot force-controlled software.

When it is used with the robot for grinding, polishing and other applications, the user only needs to input the required force value.

iGrinder® can complete the force control and floating functions by itself.

The robot only needs to move according to the teaching track.

The intelligent force-controlled grinding can be realized easily.



iGrinder®

iGrinder® is suitable for grinding, polishing, deburring and other applications, and has a wide range of applications in foundry, hardware processing and non-metallic surface treatment.

iGrinder® has two grinding methodologies: axial floating force control and radial floating force control.

iGrinder® has fast response speed, high force control accuracy, convenient use and high grinding efficiency. Compared with the traditional robot force control method, robot engineers no longer need to do complicated force sensor signal control procedures. Grinding work can quickly start after installing the iGrinder®.

Axial Floating Force Control

Within the allowable axial expansion and contraction range, iGrinder® always maintains a constant axial output force;

iGrinder® axial floating force control integrates a force sensor, displacement sensor and inclination sensor to sense parameters such as grinding force, floating position and grinding head attitude in real time. It has an independent control system and does not require external programs to participate in force control. A constant axial pressure can be automatically maintained no matter what grinding attitude the robot is.

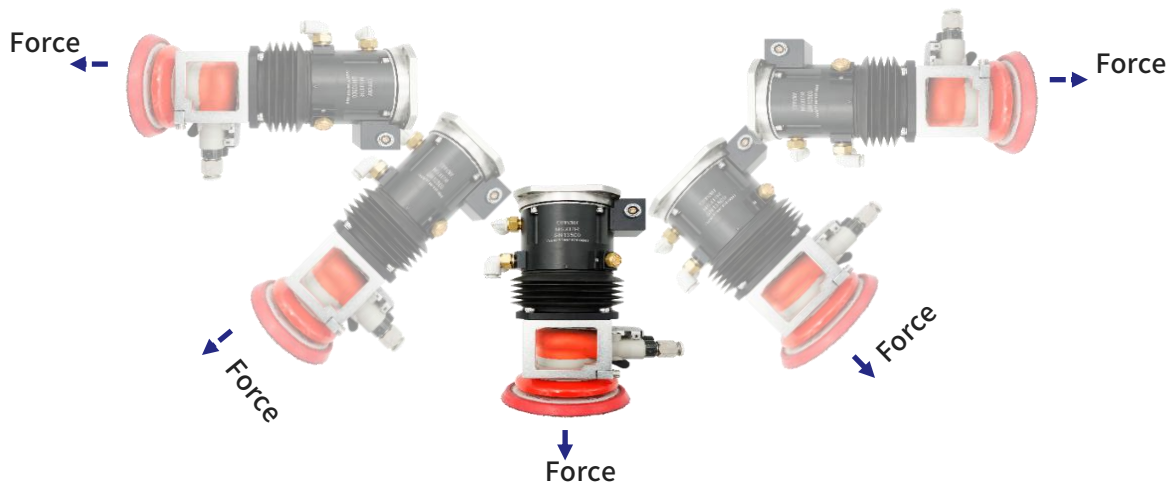

Radial Floating Force Control

Within the allowable radial float range, iGrinder® always maintains a constant radial output force;

The floating force is proportional to the air supply pressure. The pressure adjustment is realized by a precision pressure regulating valve or a proportional valve.

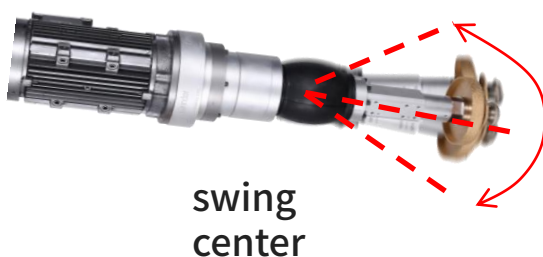

iGrinder® Axial Floating Force Control

 The iGrinder® Axial Floating Force Control can float with an axial constant force. It integrates a force sensor, a displacement sensor and an inclination sensor to sense parameters such as grinding force, floating position and grinding head attitude in real time. iGrinder® has an independent control system that does not require external programs to participate in control.

 When the iGrinder is used with the robot for grinding, polishing and other applications, the robot only needs to move according to the teaching track, and the force control and floating functions are completed by the iGrinder® itself. Users only need to enter the required force value, and the iGrinder® can automatically maintain a constant grinding pressure no matter what grinding attitude the robot is. At the same time, the iGrinder® front end can be equipped with a variety of tools for different application scenarios, such as air grinders, electric spindles, angle grinders, straight grinders, belt grinders, wire drawing machines, rotary files, etc.

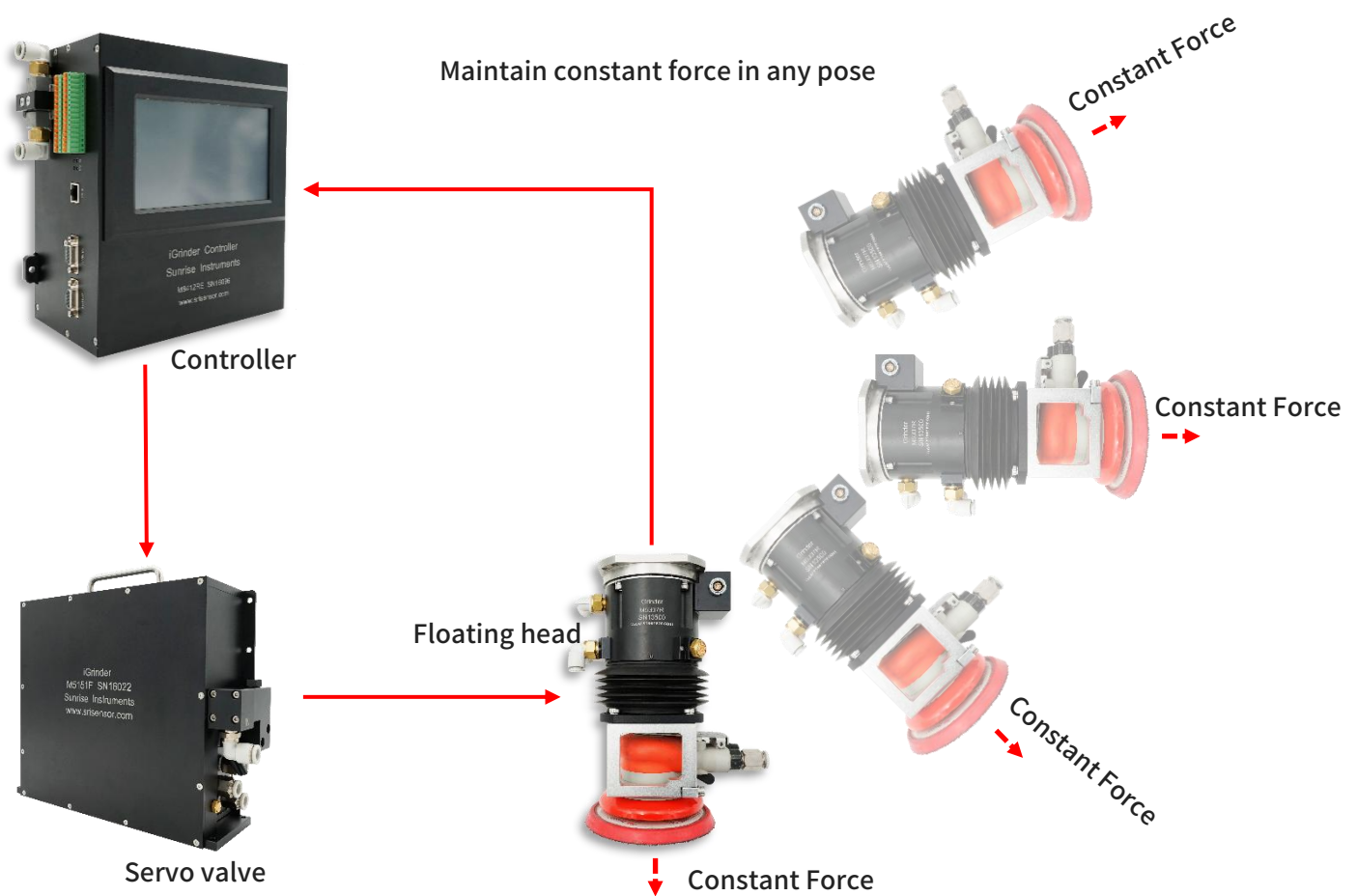

iGrinder® Axial Floating Force Control	Description
Main Feature	Axial constant force floating, independent force control system. No need for robot programming. Plug and play The grinding pressure is constant and can be adjusted in real time. The response time is 5ms, and the accuracy is +/-1N.
	Grinding/polishing tools can be arbitrarily matched according to project needs
Control Method	Integrated force sensor and tilt angle. Intelligent automatic replacement Supports Ethernet, Profinet, EtherCAT, RS232 and I/O communications
Protection Class	Special dustproof and waterproof design, suitable for harsh environments

iGrinder® Axial Floating Force Control



Selection List	M5307R12H	M5308R25H	M5308R35H	M5307R12	M5308R25	M5308R35	M5308S35
Max. Force(Push & Pull) (N)	150	300	300	150	300	300	500
Force Accuracy(N) (95% confidence interval)	+/-1	+/-1	+/-1	+/-1	+/-2	+/-2	+/-3
Stroke(mm)	12	25	35	12	25	35	35
Stroke Measurement Accuracy(mm)	0.01						
Integrated with Servo Valve	M5151F	M5151F	M5151F	M5151B	M5151B	M5151B	M5151F
Payload(Mass of Grinding Tool) (kg)	7	14	16	7	14	16	30
Max. Bending Moment - Crash(Nm)	200	250	250	200	250	250	350
Max. Torsion Moment - Crash(Nm)	200	250	250	200	250	250	350
Mass(kg)	2.4	4.6	4.8	2.4	4.6	4.8	8.3
Air Supply	Air Pressure (0.4 – 0.7MPa), Oil & Water Free, Dust Free(0.05mm), Tube Diameter 10mm						
Air Consumption	5 – 10L / Min						
Power Supply	Single Phase AC220V, 3A						
Communication - Standard	Ethernet TCP/IP, RS232, I/O						
Communication - Optional	Profinet / EtherCAT						
Protection Class	IP65						
Operation Temperature	-10 to 60°C						

General Industrial Air Grinder

Air grinder has a wide range of applications in the grinding/polishing industry. It is light weight, small, low cost, and comes with various shapes and structures, making it suitable for various operations. Attach an air grinder to the iGrinder® Intelligent Floating Head for a low-cost force-controlled floating grinding and polishing tool.

Air grinders can be purchased directly from air grinder manufacturers or supplied as a complete set by SRI.



High Power Eccentric Air Grinder

High power: Grinding pressure up to 60N. For general air grinders, the grinding disc stops when the grinding pressure is about 30N.

Test conditions: 0.6MPa air pressure, sandpaper #80

Adaptive: When the surface of the grinding disc and the workpiece do not fit, the grinding disc can automatically swing to make the them fit.



Selection List	M5915E1	M5915F1	M5915F2
Pad Size (in)	5		3
Free Speed(rpm)	9000		12000
Orbit Diameter(mm)	5		2
Air Inlet(mm)	10		8
Mass (kg)	2.9	1.3	1.6
Grinding Force(N)	Up to 60N		Up to 40N
Adaptive Angle	3° Any Orientation	N/A	3° Any Orientation
Air Pressure	0.6 – 0.8MPa		
Air Consumption	115 L/Min		
Operation Temperature	-10 to 60°C		

iCG01 Interchangeable Force-controlled Straight Grinder

 **Floating Force Control**

Integrated iGrinder®, superior floating force control function, better grinding effect, more convenient debugging, guaranteed more stable production line process.

 **Gravity Compensation**

The robot can ensure constant grinding pressure regardless grinding in any posture.

 **Automatic Tool Change**

Integrated automatic tool change function. The production line is more flexible.

 **High-speed spindle**

2.2kw, 8000rpm spindle, high power and high speed. Drives sandpaper discs, louvers, thousand impellers, grinding wheels, milling cutters ,etc.

iGrinder®
axial
floating
force
control

High speed
rotation,
interchangeable
straight grinder

Weight	Force Range	Accuracy	Floating Range	Displacement Measuring Accuracy
18kg	0 – 300N	+/-1N	0 – 25mm	0.01mm

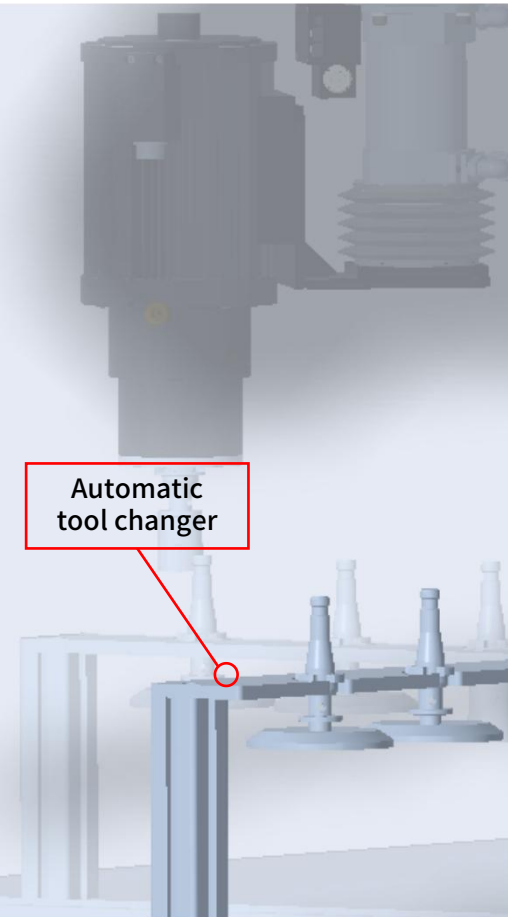
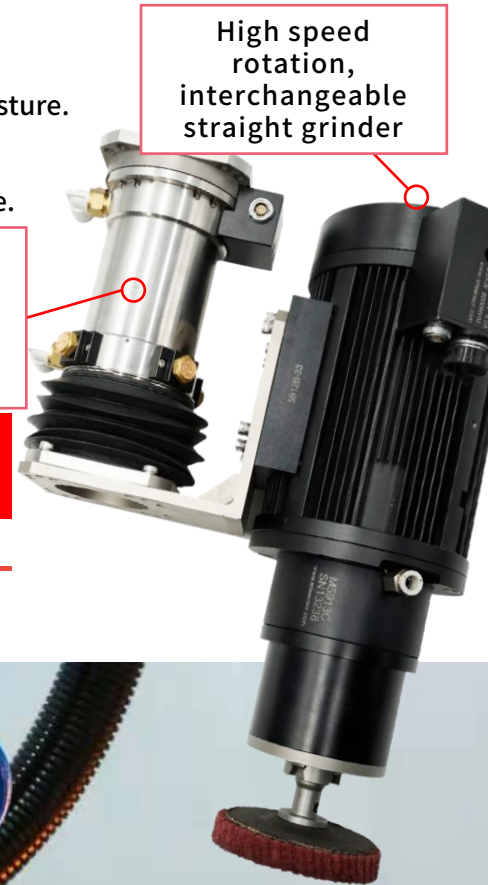

Automatic
tool changer



iCG02 Interchangeable Force-controlled Angle Grinder

Floating Force Control

Integrated iGrinder®, superior floating force control function, better grinding effect, more convenient debugging, guaranteed more stable production line process.

Gravity Compensation

The robot can ensure constant grinding pressure regardless grinding in any posture.

Automatic Tool Change

Integrated automatic tool change function. The production line is more flexible.

High-speed Spindle

2.2kw, 8000rpm spindle, high power and high speed. Drives sandpaper discs, louvers, thousand impellers, grinding wheels, milling cutters, etc.

iGrinder® axial force control

High-speed spindle, interchangeable force-controlled angle grinder

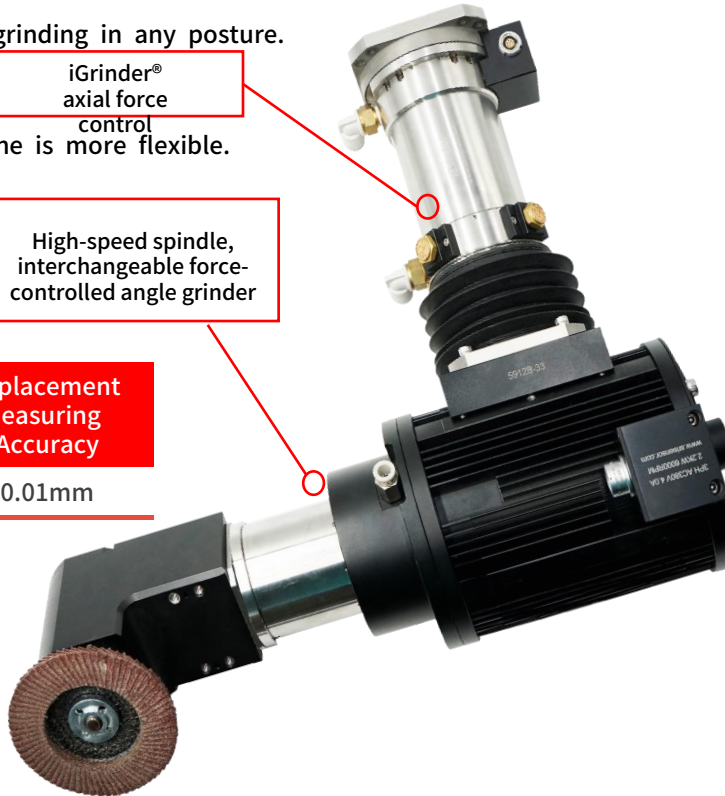

Weight	Force Range	Accuracy	Floating Range	Displacement Measuring Accuracy
21kg	0 - 300N	+/-1N	0 - 25mm	0.01mm



M5308R25D1 Eccentric Force-Controlled Straight Grinder



Floating Force Control

Integrated iGrinder®, superior floating force control function, better grinding effect, more convenient debugging, guaranteed more stable production line process.



Gravity Compensation

The robot can ensure constant grinding pressure regardless grinding in any posture.



Eccentric Spindle

The abrasive rotation axis is offset from the spindle rotation axis to minimize the interference of the motor housing on the grinding workpiece. The reduction ratio of the reduction box is 2:1, the rated output torque is 7Nm, and the maximum abrasive speed is 4000rpm.



High-speed spindle

2.2kw, 8000rpm spindle, high power and high speed. Drives sandpaper discs, louvers, thousand impellers, grinding wheels, milling cutters, etc.

Weight	Force Range	Accuracy	Floating Range	Displacement Measuring Accuracy
18kg	0 – 300N	+/-1N	0 – 25mm	0.01mm

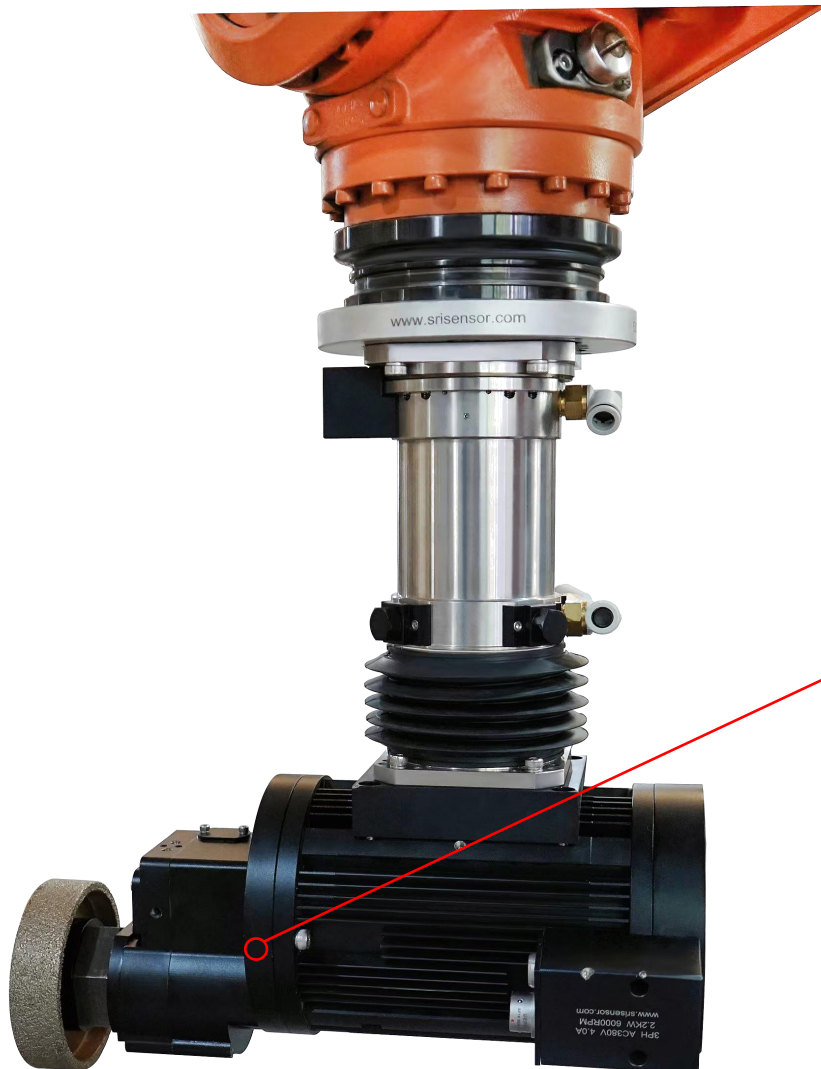

Offset output shaft
Avoid interference between the motor and workpiece

M5308S35A1 Double Output Shaft Force-controlled Grinding Machine

Floating Force Control

Integrated iGrinder®, superior floating force control function, better grinding effect, more convenient debugging, guaranteed more stable production line process.

Gravity Compensation

The robot can ensure constant grinding pressure regardless grinding in any posture.

Double-abrasive design doubles the return on investment

Both ends of the main shaft come out of the shaft, one end is equipped with a grinding plate, and the other end is equipped with a wire drawing wheel; one main shaft solves two processes, and the return on investment is doubled.

Automatic Tool Change

Integrated automatic tool change function. The production line is more flexible. The grinding disc is replaced automatically, and the wire drawing wheel is replaced manually.

High-speed spindle

2.2kw, 8000rpm spindle, high power and high speed. Drives sandpaper discs, louvers, thousand impellers, grinding wheels, milling cutters, etc.

Natural air cooling

The main shaft is naturally air-cooled, no additional cooling device is required.

Weight	Force Range	Accuracy	Floating Range	Displacement Measuring Accuracy
26kg	0 – 500N	+/-3N	0 – 25mm	0.01mm

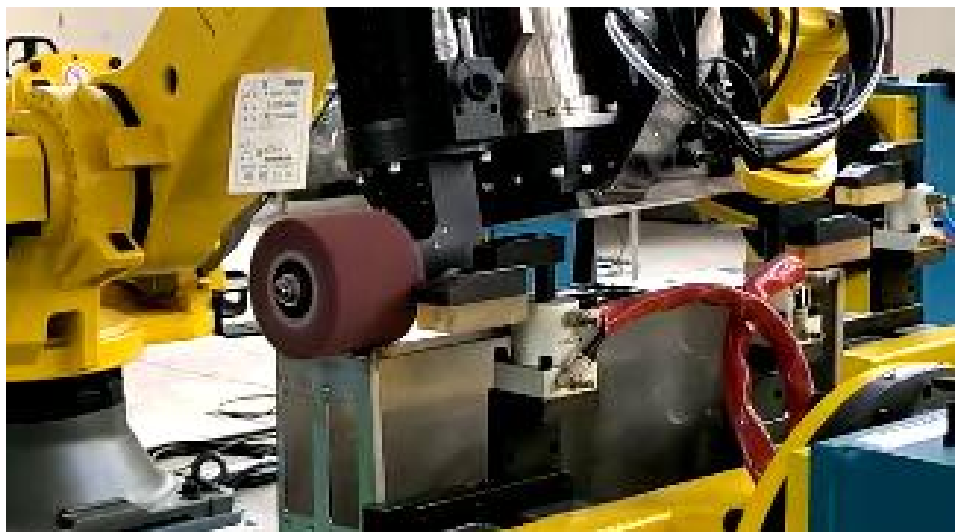
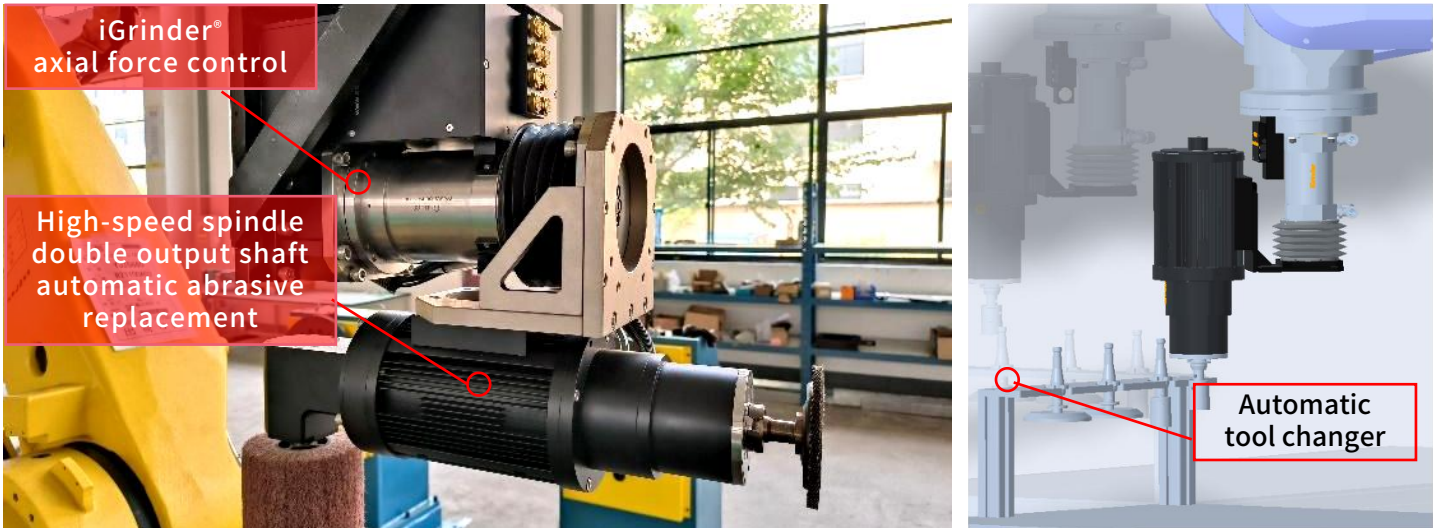

iVG Intelligent Floating Grinding Head for Vehicles

iVG is a product jointly developed by SRI and ABB for laser welding seam grinding applications on automotive roofs

Floating Force Control

Integrated iGrinder®, superior floating force control function, better grinding effect, more convenient debugging, guaranteed more stable production line process.

Gravity Compensation

The robot can ensure constant grinding pressure regardless grinding in any posture.

Abrasive Wear Compensation

Integrated displacement sensor to intelligently detect and compensate for abrasive wear.

Air-cut and power-off protection

Special protection structure, when the main power supply and gas source are suddenly turned off, automatic protection can be activated to prevent damage to the car body.

Weight	Force Range	Accuracy	Floating Range	Displacement Measuring Accuracy
20kg	0 – 200N	+/-1N	0 – 35mm	0.01mm

iGrinder®
axial force
control

Dust cover

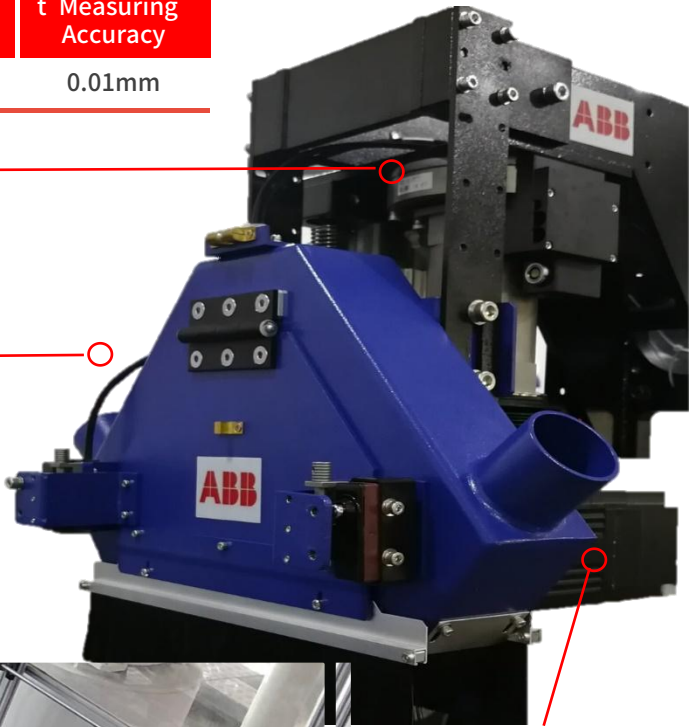

SEW moter



iBG01 Small Intelligent Force-controlled Belt Machine

iBG is an intelligent force-controlled belt grinding machine for robot. It is independently developed by SRI.

Floating Force Control

Integrated iGrinder®, superior floating force control function, better grinding effect, more convenient debugging, guaranteed more stable production line process.

Auto Belt Change

Special structure design. The abrasive belt can be replaced automatically. One belt sander for multiple processes.

Gravity Compensation

The robot can ensure constant grinding pressure when grinding in any posture.

Belt Tension Compensation

The grinding pressure is controlled by the iGrinder, and the belt tension does not affect the grinding force.

Grinding Amount Detection

Integrated displacement sensor that can automatically detect grinding amount.

Weight	Force Range	Accuracy	Floating Range	Displacement Measuring Accuracy	Belt Grinding Capability
26kg	0 – 200N	+/-1N	0 – 25mm	0.01mm	2 - 3kg stainless steel material



iBG50 Large Intelligent Force Control Belt Machine

The intelligent force-controlled belt grinder is independently developed by SRI. The belt grinder is installed on the ground, and the robot grips the workpiece for grinding and polishing.



Floating Force Control

Integrated iGrinder®, superior floating force control function, better grinding effect, more convenient debugging, guaranteed more stable production line process.

Multiple Abrasive Belt Design

Two belts included. One belt machine for more processes.

Belt Tension Compensation

The grinding pressure is controlled by iGrinder®, and the belt tension does not affect the grinding force.

Grinding Amount Detection

Integrated displacement sensor that can automatically detect grinding amount.

Power	Maximum Line Speed	Belt Width	Floating Amount	Floating Detection Accuracy	Constant Force Range	Constant Force Accuracy
3kw	40m/s	50mm	35mm	0.01mm	20 ~ 200N	+/-2N

iPG01 Force Control Polishing Machine

The force-controlled polishing machine independently developed by SRI is used for robots to hold workpieces for polishing.

Floating Force Control

Integrated iGrinder®, superior floating force control function, better grinding effect, more convenient debugging, guaranteed more stable production line process.

Double Output Shaft Design

Polishing machine has double output shaft with two polishing wheels.

Grinding Amount Detection

Integrated displacement sensor that can automatically detect grinding amount.

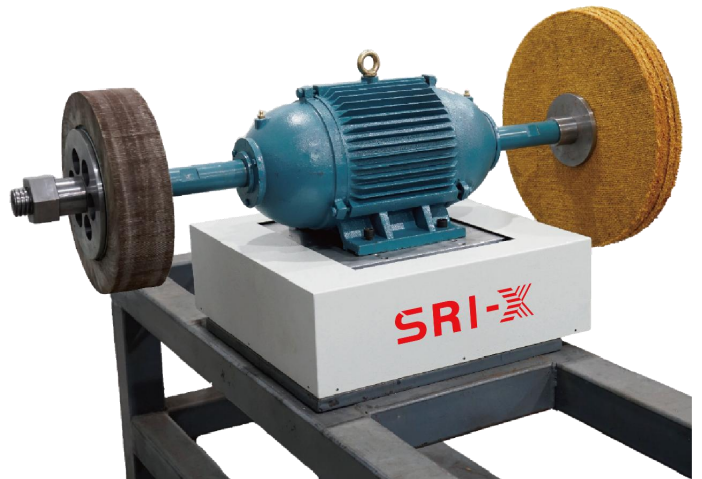

Power	Maximum Speed	Floating Amount	Floating detection accuracy	Constant Force Range	Constant Force Accuracy
5.5kw	2800rpm	35mm	0.01mm	20 ~ 200N	+/-2N

iGrinder® Radial Float Grinding Head

Heavy Duty Radial Floating Head / Interchangeable Radial Floating Head / Radial Floating Deburring Tool

iGrinder® Heavy Duty Radial Float Head

Model Number: **M5301F2**

iGrinder® Heavy Duty Radial Floating Head with integrated radial floating function, axial floating function, six-axis force sensor and displacement sensor. The radial floating force is adjusted by a precision pressure regulating valve, and the axial floating force is adjusted by a spring.

The radial force is constant, and the magnitude of the axial force is related to the amount of compression. Displacement sensors are used to monitor the radial and axial floating offsets for judging information such as contact status, grinding wheel wear, workpiece size and workpiece position. The six-axis force sensor signal can be fed back to the robot controller to provide a signal source for its force control software (such as ABB or KUKA's force control software package).

The iGrinder® Heavy Duty Radial Floating Head can easily achieve constant force grinding, and successfully solve the problem of the size difference of the workpiece and the positioning error of the tooling. Suitable for a variety of grinding application such as gate cutting, flash grinding or welding seam grinding. Its unique dust-proof design and self protection functions in abnormal working conditions make customers feel more assured.

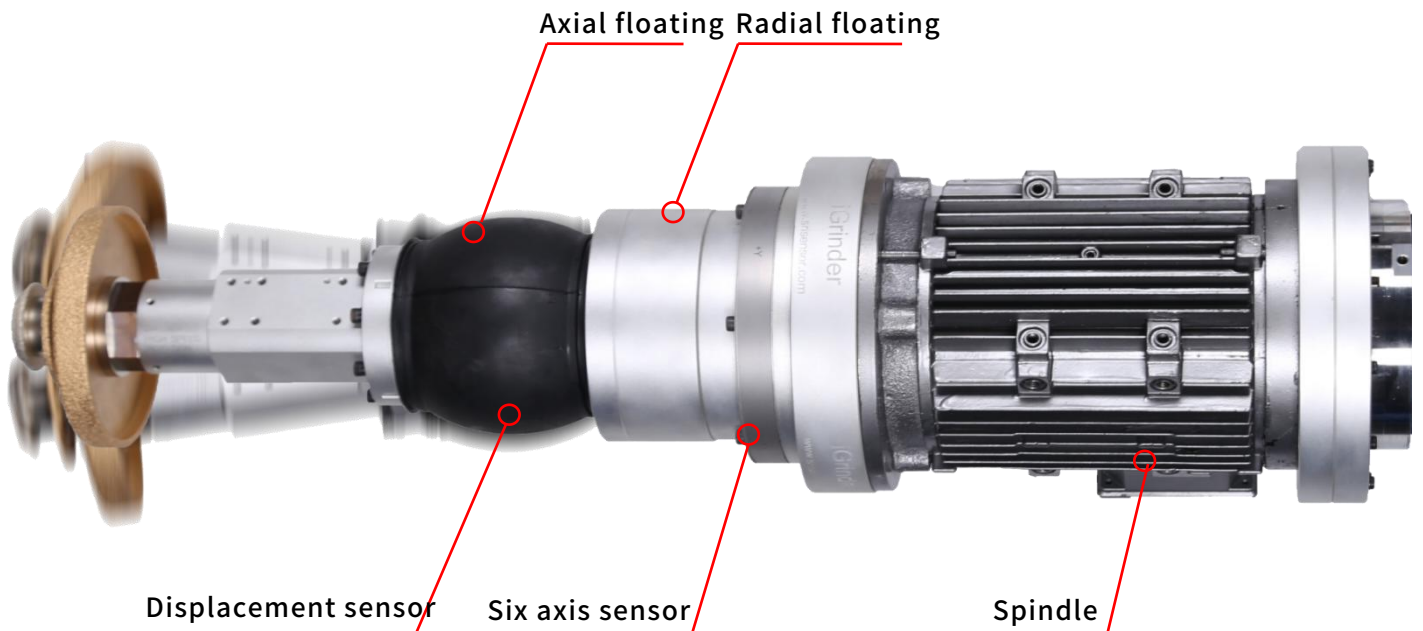

iGrinder® Heavy Duty Radial Floating Head	Description
Main Feature	Both radial and axial floating ability. Axial 16mm; radial +/- 6 degrees The grinding force is constant and can be adjusted in real time. Radial 50N to 400N, axial 30N/mm
Weight	Integrated displacement sensor, real-time feedback of floating offset; integrated six-axis force sensor, real-time monitoring of grinding force and other abnormal conditions 43kg
Motor Performance	Power 5.5kw, maximum speed 10000rpm, motor overheating protection, overload protection
Control Method	I/O control, Ethernet communication, RS232 communication, touch screen control
Protection Class	Special dust-proof design for harsh environments

iGrinder® Interchangeable Radial Floating Head**Model Number: M5302S**

The M5302S replaceable radial floating head is an intelligent grinding equipment with complete intellectual property rights of Sunrise Instruments. It has radial constant force floating capability, and the radial force is adjustable. It is designed to be plug-and-play and does not require complex programming of robots. When it is used with the robot for grinding, polishing and other applications, the robot only needs to move according to its path, and the force control and floating functions are completed by the M5302S. The user only needs to adjust the air pressure to achieve the required grinding force, and the M5302S can maintain a constant grinding pressure no matter what attitude the robot is in.

M5302S consists of a grinding spindle and a replacement tool holder. It can be equipped with a variety of abrasives such as resin grinding wheels, diamond grinding wheels, thousand impellers, grinding rings, nylon wheels, etc.

Parameter	Description
Floating Force Control	Radial constant force floating, gravity compensation, more convenient debugging, more stable production line process
Automatic tool change	Integrated automatic tool change function. The production line is more flexible
High-speed spindle	2.2kw; 8000rpm spindle. Drives a variety of abrasives
Radial Float Range	±6 degree
Gross Weight	23kg
Force Range	10 – 80N; Pressure can be adjusted online
Abrasive Maximum Outer Diameter	150mm
Protection Class	IP60. Suitable for harsh environments
Communication Method	RS232、PROFINET



Radial Floating Structure
Controls the amount of the floating force through a precision pressure regulation valve



The M5302S interchangeable radial float grinding head can be equipped with resin grinding wheels, diamond grinding wheels, flap wheels, grinding rings, nylon wheels and other abrasives, making it suitable for many different application scenarios.

iGrinder® M5302T1 Axial Radial Floating Head**Model Number : M5302T1**

The M5302T1 axial radial floating grinding head is an intelligent grinding device with complete intellectual property rights of Sunrise Instruments. It has the ability of constant force floating in the axial and radial directions, and the grinding force can be adjusted. It is plug and play and does not require complicated programming of robots.

When it is used with the robot for grinding, polishing and other applications, the robot only needs to move according to its path, and the force control and floating functions are completed by the M5302T1. The user only needs to adjust the air pressure to achieve the required grinding force. The M5302T1 can maintain a constant grinding pressure regardless of the robot attitude.

Parameter	Description
Radial Floating Force	20 – 80N; Pressure can be adjusted online
Axial Floating Force	30N/mm
Radial Floating Range	± 6 degree
Axial Floating Range	±8mm
High-speed Spindle	2.2kw, 8000rpm spindle. Drive a variety of abrasives
Gross Weight	25kg
Abrasive Maximum Outer Diameter	150mm
Protection Class	IP60
Communication Method	RS232、PROFINET

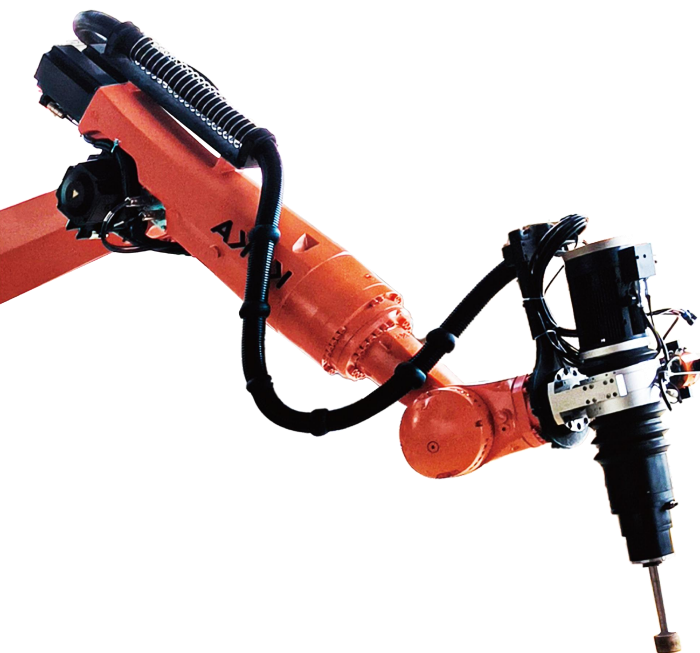

iGrinder® M5933N2 Floating Deburring Tool**Model Number : M5933N2**

The M5933N2 dual-rigidity floating deburring tool uses a 400W electric spindle with a speed of 20,000rpm as the power source. It integrates the SRI patented automatic tool changer. It provides a radial constant floating force and is an ideal choice for deburring. The radial floating has two rigidities. The X-direction rigidity is large, which can provide sufficient cutting force. The Y-direction rigidity is small, which ensures the floating contact with the workpiece while reducing the amount of overcut, effectively solving the problem of skipping and overcutting.

The radial force can be adjusted through a precise pressure regulation valve. The output air pressure of the pressure regulation valve is proportional to the size of the floating force. The greater the air pressure, the greater the floating force. Within the floating range, the floating force is constant, and the force control and floating do not require robot control. When it is used with the robot for deburring, grinding and polishing, etc., the robot only needs to move according its path, and the force control and floating functions are completed by the M5933N2. The M5933N2 maintains a constant floating force regardless of the robot's posture.

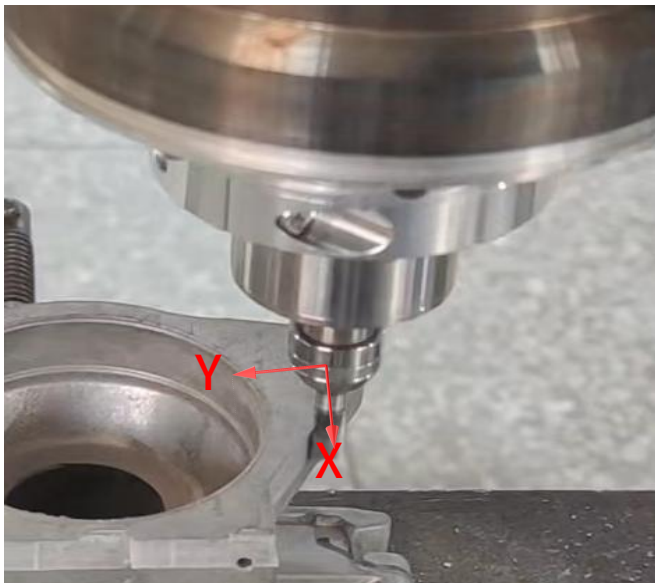

Parameter	Description
Radial Floating Force	8N – 100N
Radial Floating Range	±6 degree
Power	400W
Rated Speed	20000rpm
Minimum Speed	3000rpm
Clampable Tool Diameter	3 - 7mm
Automatic Tool Change	Pneumatic, above 0.5MPa
Spindle Cooling	Air cool
Weight	6kg

iGrinder® Floating Deburring Tool

Model Number: M5134N

Parameter	Description
Basic Information	Power 300w; no-load speed 3600rpm; air consumption 90L/min; chuck size 6mm or 3mm
Force Control Range	Axial float 5mm, 0 – 20N;
	Radial float +/-6°, 0 – 100N. Adjustable float force through precision pressure regulator
Weight	4.5kg
Features	Low cost; the floating structure and the deburring tool are independent, and the deburring tool can be replaced at will.
Protection Class	Special dustproof and waterproof design for harsh environments

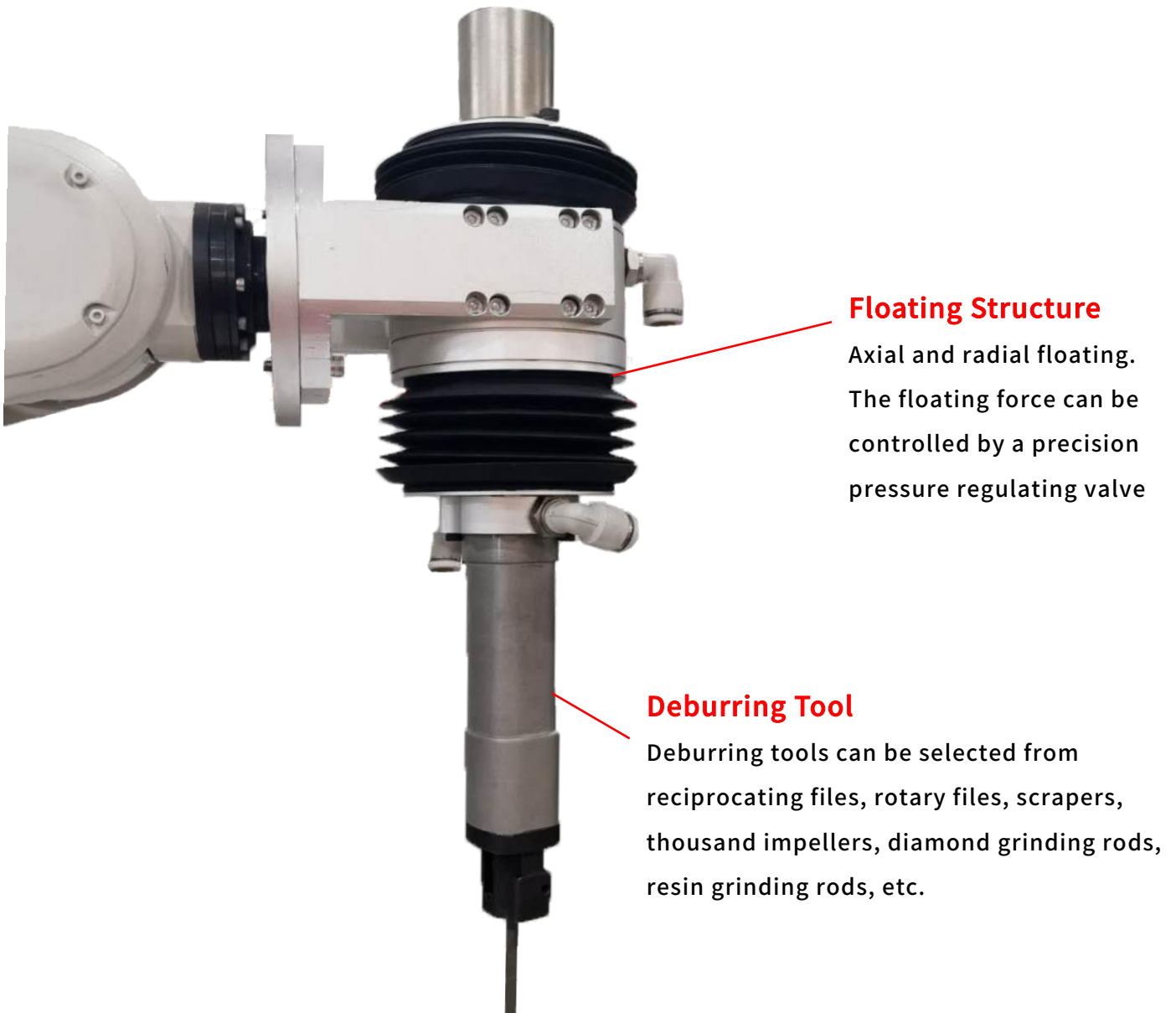

SENSE AND CREATE



USA Office
8534 N Canton Center Rd
Canton, MI 48187, USA
Tel: +1-248-974-0597
Email: cherryli@srisensor.com



China Main Office
No.176, Gaoji Rd, Shanghai, China
China Factory
B2 Block, No. 19, Ke Yuan Xi Shi Rd,
Nanning, China
Tel: +86-21-6127-6380
Email: sri@srisensor.com



Korea
Kyoung- Tea Min, KTINC
Rm 1406, ACE Pyeongchon Tower
361 SIMIN-DAERO, DONGAN-GU
ANYANG-SI, GYEONGGI-DO, S. KOREA
Mobile : 010-8650-8498
Tel : +31-383-8498
Email: ktmin@ktinc.kr



Taiwan
John Pai, MEMS TECHNOLOGY CORP.
6F., No. 192, Sec.3, Chongyang Rd.,
Sanchong Dist., New Taipei City 241
Tel : +886-2-2982-1580 ext.215
Mobile : +886-920-306060
Email: john.pai@memstec.com.tw