

DIRECTLY MOUNTED TO LIGHT-WEIGHT 1GRINDER
M5307A, M5307R, M5308BM5308C, M5308R25, M5308R35

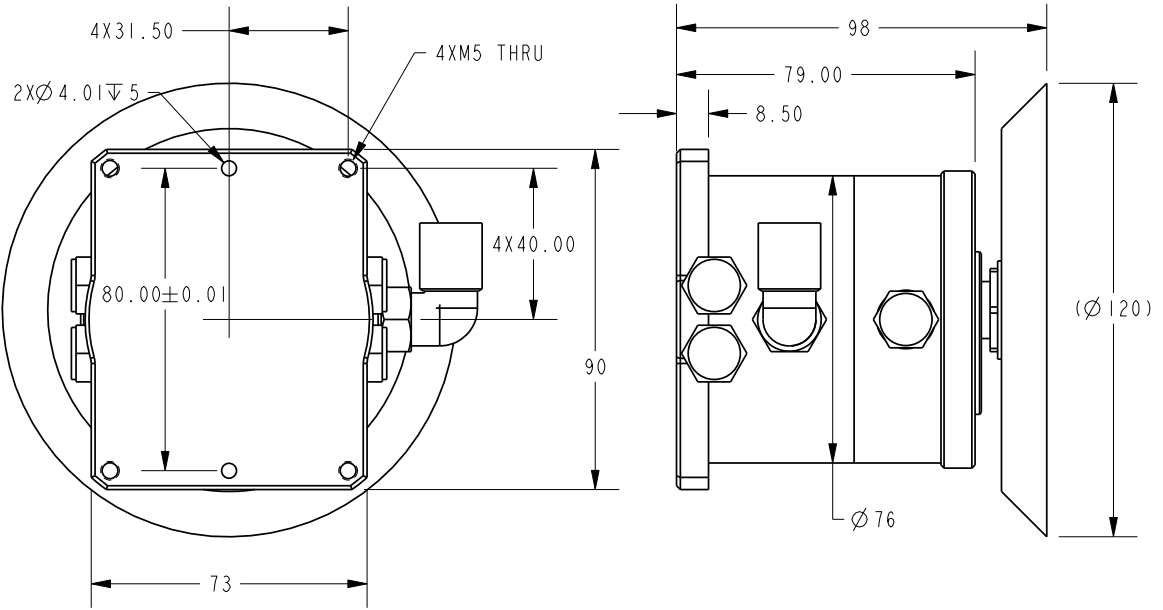
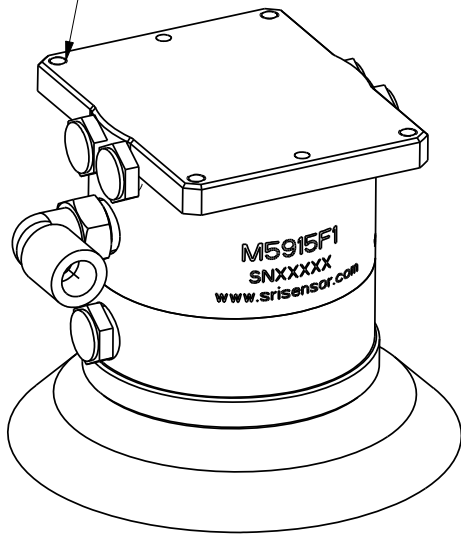

HIGH POWER:
SANDER PAD ROTATION WILL NOT STOP AT GRINDING FORCE 60N, FOR #80 SAND PAPER UNDER AIR PRESSURE 0.6MPA. FOR COMPARISON, GRINDING FORCE FOR A TYPICAL PNEUMATIC ORBITAL SANDER IS LESS THAN 30N

SPECIFICATIONS

PAD SIZE	5"
FREE SPEED	9000 RPM
ORBIT DIAMETER	5 MM
AIR INLET	10 MM
MASS	1.3 KG
GRINDING FORCE	UP TO 60N
AIR PRESSURE	0.6-0.8MPA
AIR CONSUMPTION	115 L/MIN
OPERATION TEMPERATURE	-10 TO 60°C
ADAPTIVE ANGLE	N/A

SUNRISE INSTRUMENTS

www.srisensor.com

PNEUMATIC ORBITAL SANDER
5" PAD, HIGH POWER

UNLESS OTHERWISE SPECIFIED
DIMENSIONS ARE IN MM

M5915F1

REV.
A