

3X2XM4 ∇ 6
DO NOT EXCEED 6MM DEEP
TORQUED TO 3~5NM

CABLE #1
0.5M LENGTH
ETHERCAT
CABLE
0.5M LENGTH

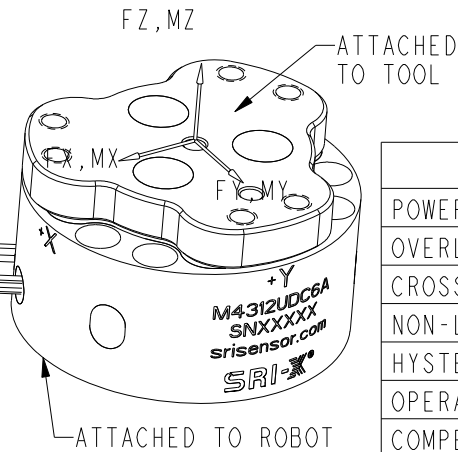

ETHERCAT CABLE			
COLOR	FUNCTION	REMARK	SIZE
ORANGE	TXPB	ETHERCAT OUT	30 AWG
BLACK	TXNB		
GRAY	RXPB		
BROWN	RXNB		
BLUE	TXPA	ETHERCAT IN	
WHITE	TXNA		
YELLOW	RXPA		
GREEN	RXNA		

CABLE #1		
COLOR	FUNCTION	SIZE
BLUE	22~50V(DC)	26 AWG
BLUE&WHITE	GND	26 AWG
GRAY	RS232_RX	30 AWG
BROWN	RS232_TX	
BLACK	SHIELD	

SPECIFICATIONS	
POWER SUPPLY	22~50V(DC)
OVERLOAD CAPACITY (%F.S.)	250
CROSSTALK (%F.S.)	2.5
NON-LINEARITY (%F.S.)	0.5
HYSTERESIS (%F.S.)	0.5
OPERATING TEMP. RANGE (°C)	-40 TO +90
COMPENSATED TEMP. RANGE (°C)	10 TO 70
IP PROTECTION	IP60
MASS (KG)	0.185

SUNRISE INSTRUMENTS
www.srisensor.com

SIX AXIS CIRCULAR LOAD CELL
D45MM F300N, ETHERCAT, DC DC CONVERTER

	Fx	Fy	Fz	Mx	My	Mz
CAPACITY (N/Nm)	300.0	300.0	300.0	30.0	30.0	30.0

UNLESS OTHERWISE SPECIFIED DIMENSIONS ARE IN MM	M4312UDC6A	REV. 0.2
--	------------	-------------