

POSITIVE OUTPUT WHEN THE LOADING IS APPLIED TO THE TOOL SIDE OF THE LAODCELL, PER COORDINATE SYSTEM AS SHOWN

CHANNELS ARE COUPLED, AND DECOUPLED MATRIX ARE PROVIDED

	Fx	Fy	Fz	Mx	My	Mz
<b>CAPACITY (N/Nm)</b>	300.0	300.0	300.0	6.0	6.0	6.0
<b>OUTPUT (mV/V)</b>	COUPLED OUTPUT					
<b>BRIDGE RES. (Ω)</b>	900	900	900	900	900	900

**WIRING CODE (14-CONDUCTOR CABLE)**

NO.	COLOR	FUNCTION	NO.	COLOR	FUNCTION	NO.	COLOR	FUNCTION
1	WHITE	CH1+	6	LIGHT YELLOW	CH3-	11	PURPLE	CH6+
2	BROWN	CH1-	7	GREEN	CH4+	12	LIGHT PURPLE	CH6-
3	ORANGE	CH2+	8	GRAY	CH4-	13	RED	+E
4	LIGHT ORANGE	CH2-	9	BULE	CH5+	14	BLACK	-E
5	YELLOW	CH3+	10	LIGHT BLUE	CH5-			

SHIELD TO SENSOR BODY

**SPECIFICATIONS**

EXCITATION MAX. (V)	10
OVERLOAD CAPACITY (%F.S.)	200
CROSSTALK (%F.S.)	2.5
NON-LINEARITY (%F.S.)	1.0
HYSTERESIS (%F.S.)	1.0
COMPREHENSIVE ACCURACY (%F.S.)	2.5
OPERATING TEMP. RANGE (°C)	-40 TO +90
MASS (KG)	0.036

**SUNRISE INSTRUMENTS**

[www.srisensor.com](http://www.srisensor.com)

SIX AXIS CIRCULAR LOAD CELL  
EXTRA THIN, COUPLED, D30MM F300N

UNLESS OTHERWISE SPECIFIED  
DIMENSIONS ARE IN MM

CO30F300F

REV.  
A

# MATING PARTS (MATERIAL: ALUMINUM)

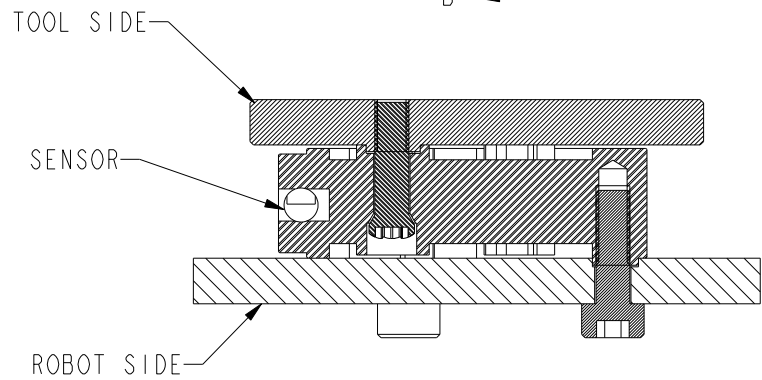
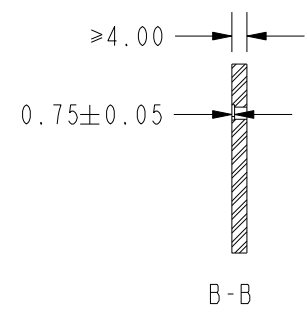
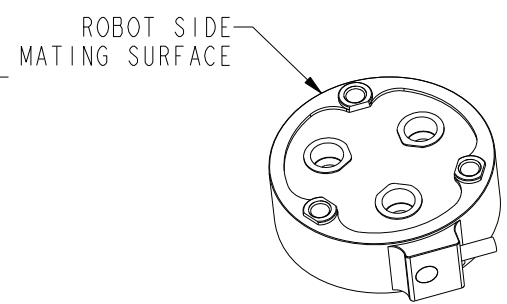
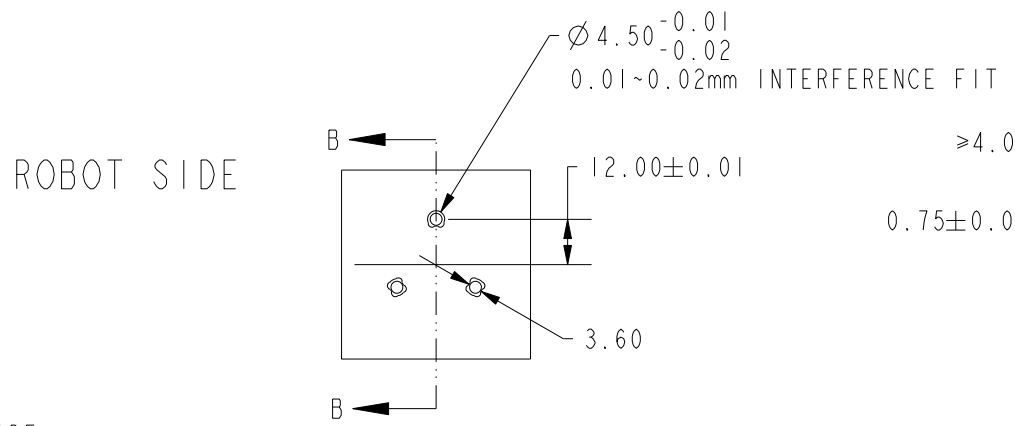
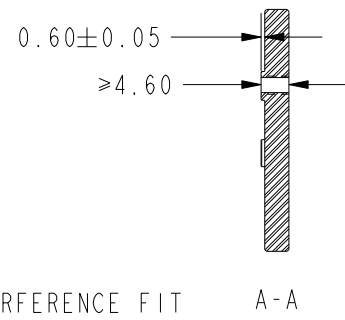
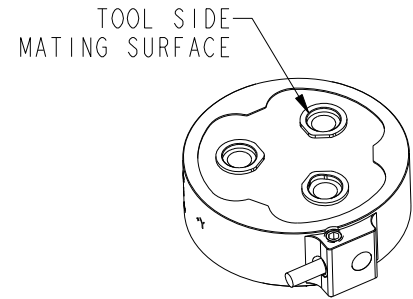
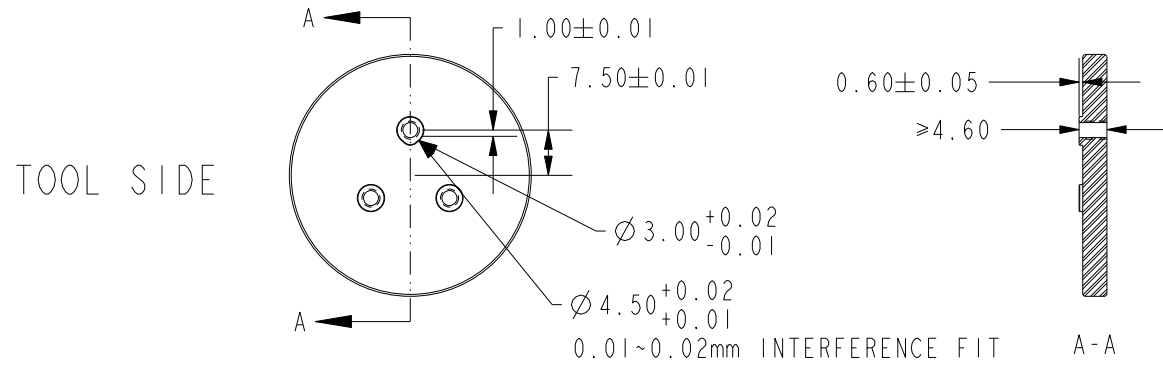

<b>SUNRISE INSTRUMENTS</b> <a href="http://www.srisensor.com">www.srisensor.com</a>		
SIX AXIS CIRCULAR LOAD CELL EXTRA THIN, COUPLED, D30MM F300N (PAGE 2)		
UNLESS OTHERWISE SPECIFIED DIMENSIONS ARE IN MM	C030F300F	REV. A