

iGR IN DEF



DIRECTORY

1 iGrinder®

2 Selection Guide

2 Axial Floating Force Control

7 Interchangeable Force-controlled Straight Grinder
M5308R25GA1

8 Interchangeable Force-controlled Angle Grinder
M5307R25GB1

9 Interchangeable Force-controlled Straight Grinder
M5308T35GA3

10 Double Output Shaft Force-controlled Grinder
M5308T35GA4

11 Eccentric Force-Controlled Straight Grinder
M5308R25GD1

12 Interchangeable Force-controlled Straight Grinder
iCG11

13 Intelligent Floating Grinding Head for Vehicles
iVG

14 Small Intelligent Force-controlled Belt Machine
iBG01

15 Large Intelligent Force Control Belt Machine
iBG51

16 Force Control Polishing Machine
iPG01

3 Radial Floating Force Control

18 Interchangeable Radial Floating Head
M5302S

19 Axial Radial Floating Head
M5302T1

4 Floating Deburring Tool

20 Floating Deburring Tool
M5933N

21 Floating Deburring Tool
M5134N

4 Grinding tools and related products

23 Electric spindle tool holder

23 Automatic tool changer magazine

24 Automatic sandpaper changing warehouse

24 Electrical control cabinet

Selection Guide

Applicable scenarios: Grinding, polishing, deburring and other applications, in casting, hardware processing and non-metallic surface treatment, etc

iGrinder® is an independent force-controlled grinding system that does not rely on robot manual control software. When used in conjunction with robots for applications such as grinding and polishing, users only need to input the required force value. iGrinder® will automatically complete the force control and floating functions. The robot only needs to move along the teaching trajectory to easily achieve intelligent and controllable grinding.

iGrinder® Axial Floating Force Control

Within the allowable axial expansion and contraction range, iGrinder® always maintains a constant axial output force. iGrinder® axial floating force control integrates a force sensor, displacement sensor and inclination sensor to sense parameters such as grinding force, floating position and grinding head attitude in real time. It has an independent control system and does not require external programs to participate in force control. A constant axial pressure can be automatically maintained no matter the grinding attitude.

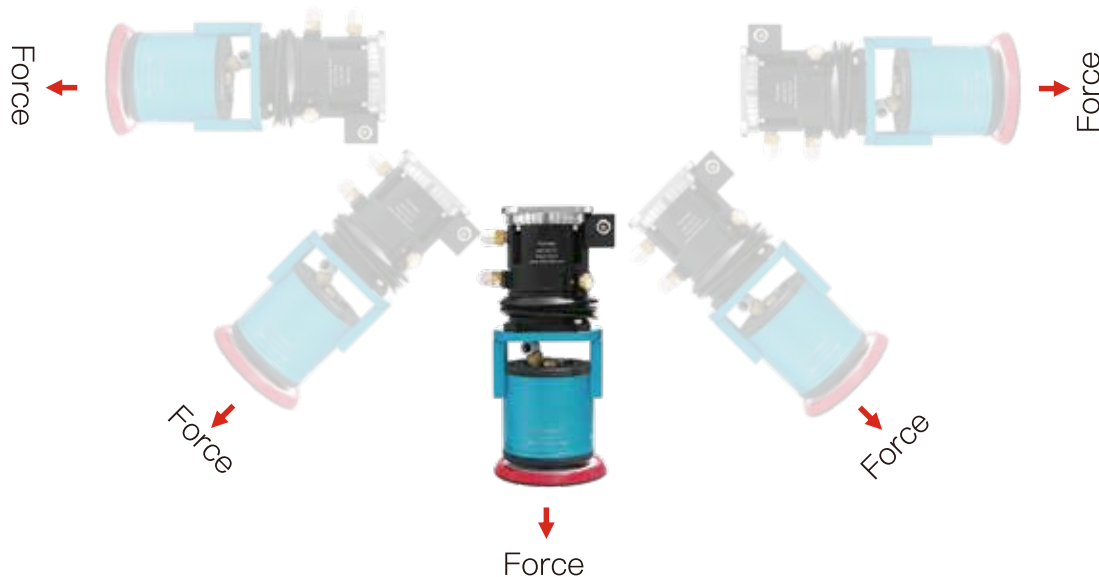

Radial Floating Force Control

Within the allowable radial float range, iGrinder® always maintains a constant radial output force. The floating force is proportional to the air supply pressure and pressure adjustment is realized by a precision pressure regulation valve.

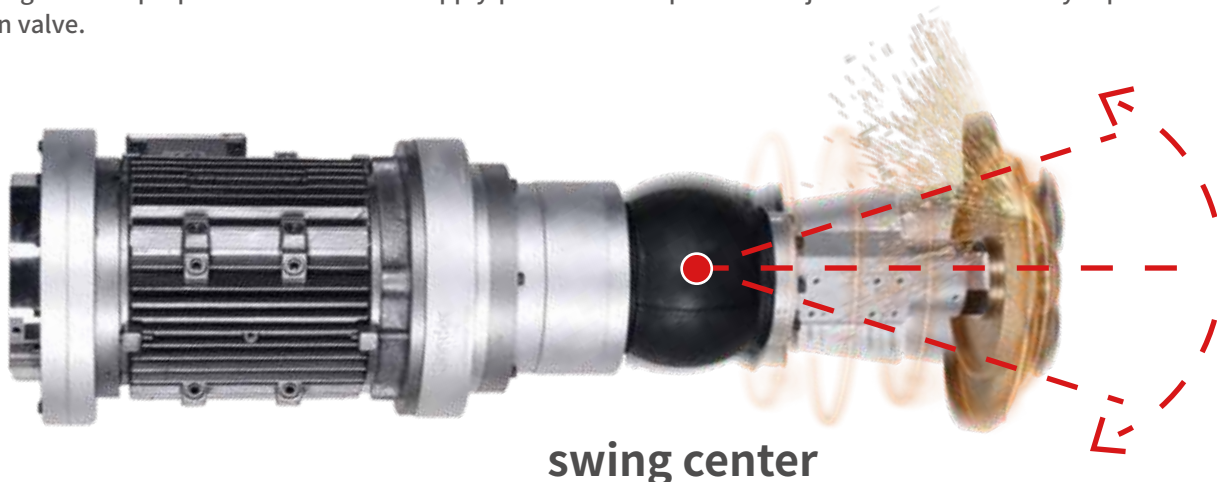

iGrinder®

Axial Floating Force Control

iGrinder® Axial Floating Force Control

The iGrinder® Axial Floating Force Control can float with an axial constant force. It integrates a force sensor, a displacement sensor and an inclination sensor to sense parameters such as grinding force, floating position and grinding head attitude in real time. iGrinder® has an independent control system that does not require external programs to participate in control. When the iGrinder is used with the robot for grinding, polishing and other applications, the robot only needs to move according to the programmed path, and the force control and floating functions are completed by the iGrinder® by itself. Users only need to enter the required force value, and the iGrinder® can automatically maintain a constant grinding pressure invariant of the grinding attitude. At the same time, the iGrinder® front end can be equipped with a variety of tools for different application scenarios, such as air grinders, electric spindles, angle grinders, straight grinders, belt grinders, wire drawing machines, rotary files, etc.

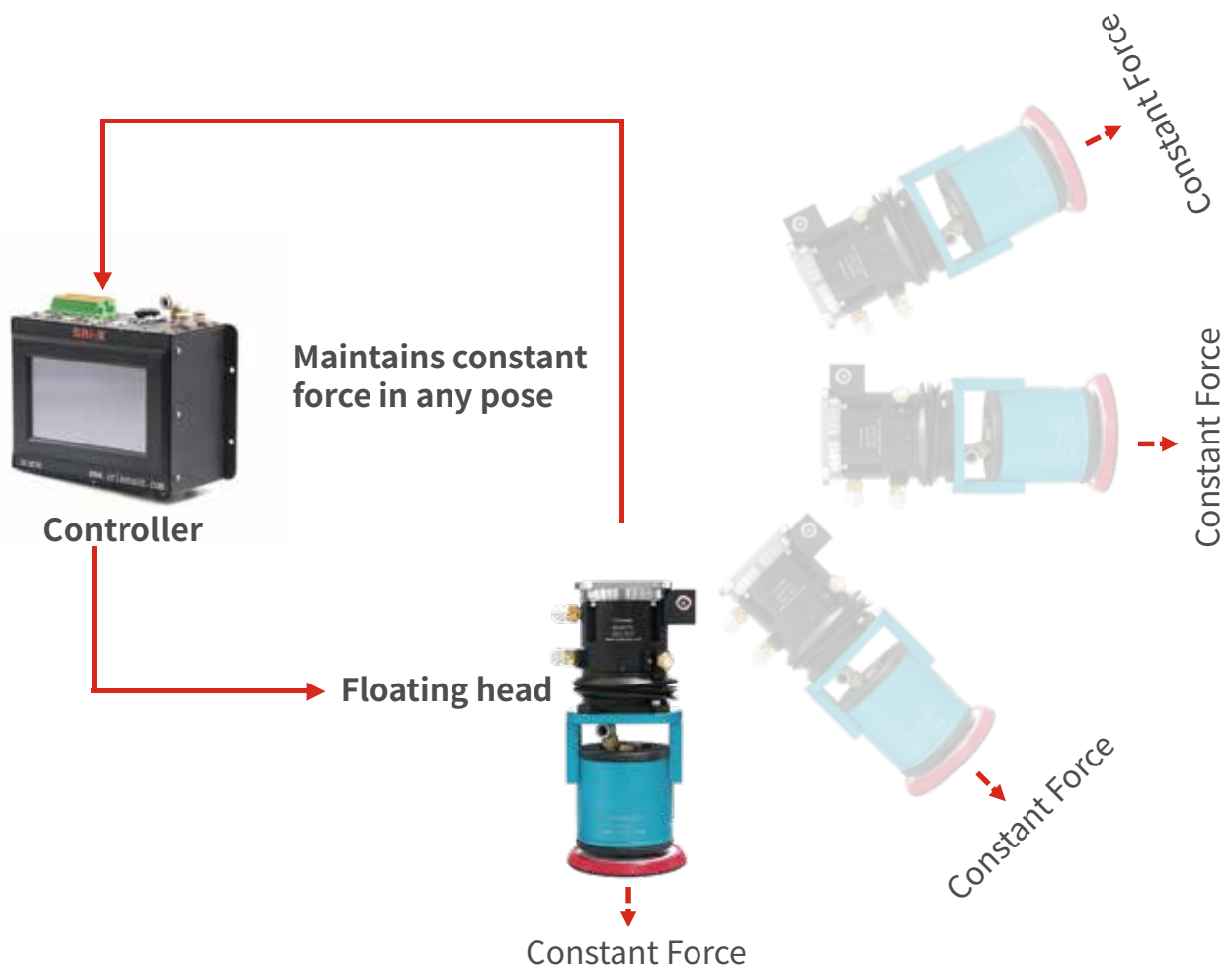

Parameters

iGrinder® Axial Floating Force Control	Description
Main Feature	Axial constant force floating, independent force control system. No need for robot programming. Plug and play The grinding pressure is constant and can be adjusted in real time. The response time is 5ms, and the accuracy is +/-1N. Grinding/polishing tools can be arbitrarily matched according to project needs
Control Method	Integrated force sensor and tilt angle. Intelligent automatic replacement
Protection Class	Supports Ethernet, Profinet, EtherCAT, RS232 and I/O communications Special dustproof and waterproof design, suitable for harsh environments

*The product is subject to the actual sample. SRI reserves the right to improve the appearance and design of the product.

iGrinder[®]

Axial Floating Force Control

Selection Guide

M5308R50G

Stroke:50mm
Force Accuracy:±/-1.5N

M5308R35G

Stroke:35mm
Force Accuracy:±/-1.5N

M5308R25G

Stroke:25mm
Force Accuracy:±/-1N

M5308T35G

Stroke:35mm
Force Accuracy:±/-3N

M5307S20

Stroke:20mm
Force Accuracy:±/-1N

M5307R12G

Stroke:12mm
Force Accuracy:±/-1N

Parameters

Selection List	M5307R12G	M5307R12GH	M5307S20G	M5308R25G	M5308R35G	M5308R50G	M5308T35G
Max. Force(Push & Pull) (N)	150	150	25	300	300	300	500
Force Accuracy(N)(95% confidence interval)	±/-1	±/-0.5	±/-1.5	±/-1	±/-1.5	±/-1.5	±/-3
Stroke(mm)	12	12	20	25	35	50	35
Stroke measurement Accuracy(mm)	0.01						
Integrated with Servo Valve	M8415R	M8415R	M8415R	M8415R	M8415R	M8415R	M8415T
Payload(Mass of Grinding Tool) (kg)	7	7	2	14	16	16	30
Max. Bending Moment - Crash(Nm)	200	200	180	250	250	250	350
Max. Torsion Moment - Crash(Nm)	200	200	180	250	250	250	350
Mass(kg)	2.4	2.4	1.9	4.6	4.8	5.1	12.85
Air Consumption	260L/Min	260L/Min	260L/Min	200L/Min	200L/Min	200L/Min	250L/Min
Air Supply	Air Pressure (0.4 – 0.5MPa), Oil & Water Free,Dust Free(0.05mm), Tube Diameter 10mm						
Power Supply	DC 24V, 2A						
Communication - Standard	Ethernet TCP/IP, RS232, I/O						
Communication - Optional	Profinet / EtherCAT/ModbusTCP						
Protection Class	IP65						
Operation Temperature	-10°C to 60°C						

*The product is subject to the actual sample. SRI reserves the right to improve the appearance and design of the product.

iGrinder®

General Industrial Air Grinder

Advantage

01

Floating force control

Integrated iGrinder® Superior floating force control function
The polishing effect is better

02

Gravity compensation

Polishing in any posture
All can maintain constant force grinding Pressure

03

Diverse tools

Compatible with various pneumatic mills
Meet different process requirements

04

Automatic abrasive replacement

Automatic abrasive replacement
Provide a sandpaper refilling warehouse

General Industrial Air Grinder

Air grinders have a wide range of applications in the grinding/polishing industry. It is light weight, small, low cost, and comes with various shapes and structures, making it suitable for various operations.

Attach an air grinder to the iGrinder® Intelligent Floating Head for a low-cost force-controlled floating grinding and polishing tool.

Air grinders can be purchased directly from air grinder manufacturers or supplied as a complete set by SRI.



High Power Eccentric Air Grinder

High power: Grinding pressure up to 60N. For general air grinders, the grinding disc stops when the grinding pressure is about 30N.

Test conditions: 0.6MPa air pressure, sandpaper #80

Adaptive: When the surface of the grinding disc and the workpiece do not fit, the grinding disc can automatically swing to make them fit.



Parameters

Selection List	M5915E1	M5915F1	M5915F2
Pad Size (in)	5	5	3
Free Speed(rpm)	9000	9000	12000
Orbit Diameter(mm)	5	5	2
Air Inlet(mm)	10	10	8
Mass(kg)	2.9	1.3	1.6
Grinding Force(N)	Up to 60N	Up to 60N	Up to 40N
Adaptive Angle	3°Any Orientation	N/A	3°Orientation
Air Pressure		0.6-0.8MPa	
Air Consumption		115L/Min	
Operation Temperature		-10 to 60°C	

*The product is subject to the actual sample. SRI reserves the right to improve the appearance and design of the product.



iGrinder[®]

Axial Floating Force Control

iGrinder[®] is suitable for applications such as grinding, polishing, and deburring, and is widely used in fields like casting, metalworking, and non-metallic surface treatment. iGrinder[®] has a faster response speed, higher force control accuracy, is more convenient to use, and has a higher grinding efficiency. Compared with traditional robot manual control methods, robot engineers no longer need to develop complex force sensor signal control programs. By installing iGrinder[®], they can quickly carry out grinding work. iGrinder[®] is divided into axial buoyancy control and radial buoyancy control.

iCG01

Number:M5308R25GA1

Interchangeable Force-controlled Straight Grinder

Performance

Control mode

ETHERNET、Profinet、EtherCAT
RS232、I/O

High-speed spindle

2.2kw/8000rpm

Floating force control

Integrated iGrinder®
Superior floating force control function
The polishing effect is better

An automatic tool changer is optional

Integrated automatic tool changing system
The production line is more flexible

A variety of knife heads

It can be equipped with sandpaper discs, louvers and thousand-blade wheels
Grinding wheels, milling cutters, etc

Advantage

01

Floating force control

Integrated iGrinder®
Superior floating force control function
The polishing effect is better**02**

Gravity compensation

Polishing in any posture
All can maintain constant force grinding Pressure**03**

Automatic tool changing

Integrated automatic tool changing function
The production line is more flexible**04**

High-speed spindle

2.2kw/8000rpm

Application



Parameter

Weight	Force range	Accuracy	Floating Range	Displacement Measuring Accuracy
18kg	0-300N	+/-1.5N	0-25mm	0.01mm

*The product is subject to the actual sample. SRI reserves the right to improve the appearance and design of the product.

iCG02

Number:M5308R25GB1

Interchangeable Force-controlled Angle Grinder

Performance

Floating force control

Integrated iGrinder®
Superior floating force control function
The polishing effect is better

An automatic tool changer is optional

Integrated automatic tool changing system
The production line is more flexible

A variety of knife heads

It can be equipped with sandpaper discs, louvers and thousand-blade wheels
Grinding wheels, milling cutters, etc

High-speed spindle

2.2kw/8000rpm

Control mode

ETHERNET, Profinet, EtherCAT
RS232, I/O

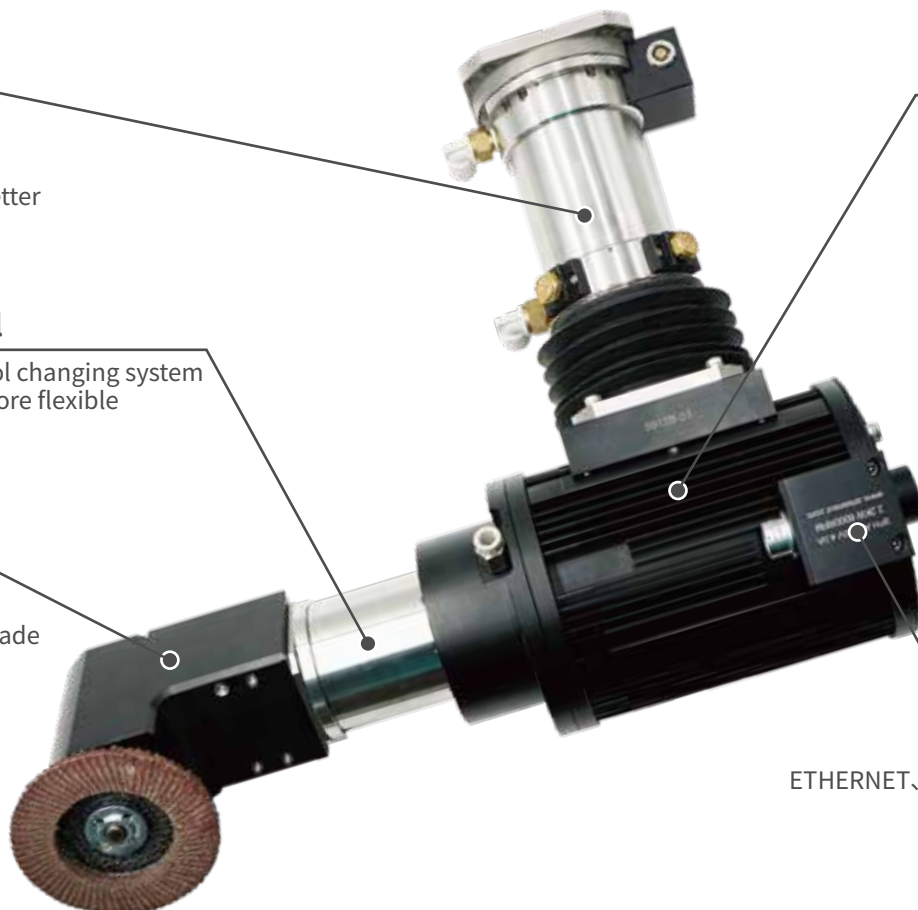

Advantage

01

Floating force control

Integrated iGrinder®
Superior floating force control function
The polishing effect is better

02

Gravity compensation

Polishing in any posture
All can maintain constant force grinding Pressure

03

Automatic tool changing

Integrated automatic tool changing function
The production line is more flexible

04

High-speed spindle

2.2kw/8000rpm

Application



Parameter

Weight	Force range	Accuracy	Floating Range	Displacement	Measuring Accuracy
18kg	0-300N	+/-1.5N	0-25mm		0.01mm

*The product is subject to the actual sample. SRI reserves the right to improve the appearance and design of the product.

iCG03

Number:M5308R35GA3

Interchangeable Force-controlled Straight Grinder

Performance

Control mode

ETHERNET, Profinet
EtherCAT, RS232, I/O

An automatic tool changer is optional

Integrated automatic tool changing system
The production line is more flexible

A variety of knife heads

It can be equipped with sandpaper discs, louvers and thousand-blade wheels
Grinding wheels, milling cutters, etc

Floating force control

Integrated iGrinder®
Superior floating force control function
The polishing effect is better

High-speed spindle

6kw/18000rpm

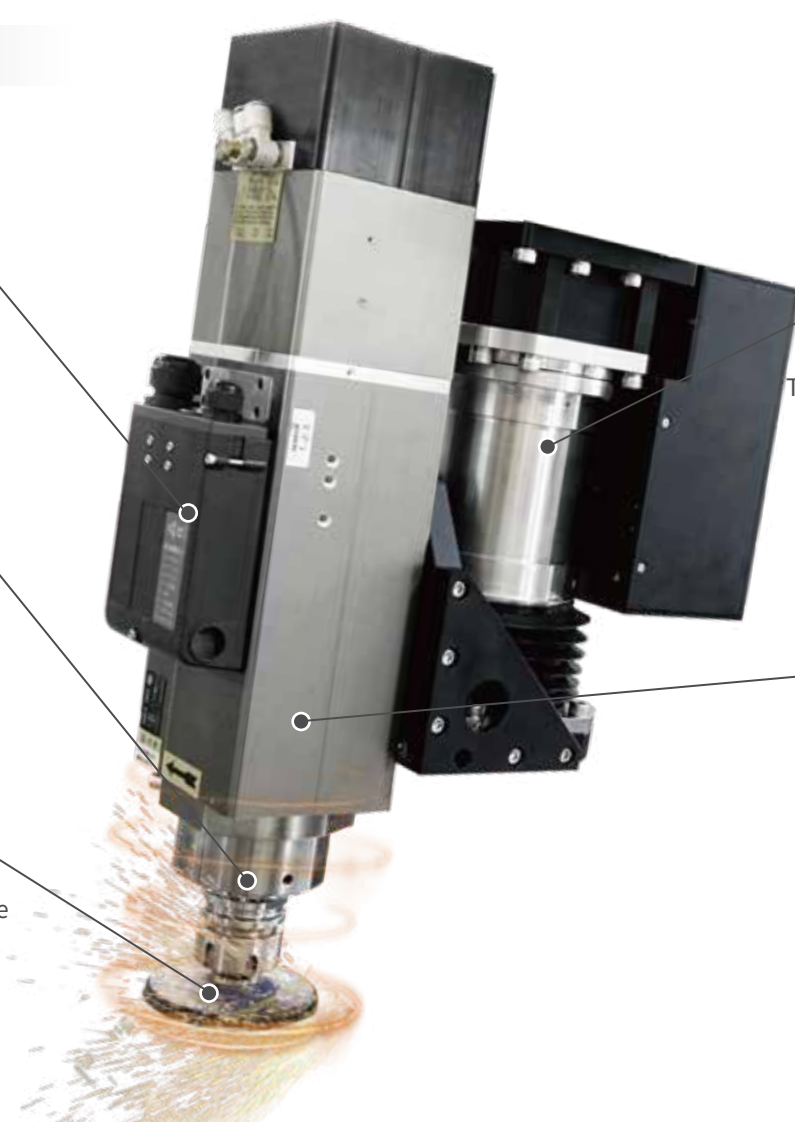

Advantage

01

Floating force control

Integrated iGrinder®
Superior floating force control function
The polishing effect is better

02

Gravity compensation

Polishing in any posture
All can maintain constant force grinding Pressure

03

Automatic tool changing

Integrated automatic tool changing function
The production line is more flexible

04

High-speed spindle

6kw/18000rpm

Application



Parameter

Weight	Force range	Accuracy	Floating Range	Displacement	Measuring Accuracy
32.5kg	0-500N	+/-3N	0-35mm		0.01mm

*The product is subject to the actual sample. SRI reserves the right to improve the appearance and design of the product.

iCG04

Number:M5308T35GA4

Double Output Shaft Force-controlled Grinder

Performance



Double abrasive design

One spindle solves two processes
The return on investment has doubled

Floating force control

Integrated iGrinder®
Superior floating force control function
The polishing effect is better

An automatic tool changer is optional

Integrated automatic tool changing system
The production line is more flexible

Natural air cooling

No additional cooling device is required

High-speed spindle

2.2kw/8000rpm

A variety of knife heads

It can be equipped with sandpaper discs, louvers and thousand-blade wheels
Grinding wheels, milling cutters, etc

Advantage

01

Floating force control

Integrated iGrinder®
Superior floating force control function
The polishing effect is better

02

Gravity compensation

Polishing in any posture
All can maintain constant force grinding Pressure

03

Double abrasive design

One spindle solves two processes
The return on investment has doubled

04

High-speed spindle

2.2kw/8000rpm

Application



Parameter

Weight	Force range	Accuracy	Floating Range	Displacement	Measuring Accuracy
26kg	0-500N	+/-3N	0-35mm		0.01mm

*The product is subject to the actual sample. SRI reserves the right to improve the appearance and design of the product.

iCG05

Number:M5308R25GD1

Eccentric Force-Controlled Straight Grinder

Performance

High-speed spindle

2.2kw/8000rpm

A variety of knife heads

It can be equipped with sandpaper discs, louvers and thousand-blade wheels
Grinding wheels, milling cutters, etc

Floating force control

Integrated iGrinder®
Superior floating force control function
The polishing effect is better

Eccentric Spindle

The abrasive rotation is offset from the spindle rotation axis to minimize the interference of the motor housing on the grinding workpiece. Gearbox reduction ratio 2:1, rated output torque 7Nm, maximum abrasive speed 4000rpm.

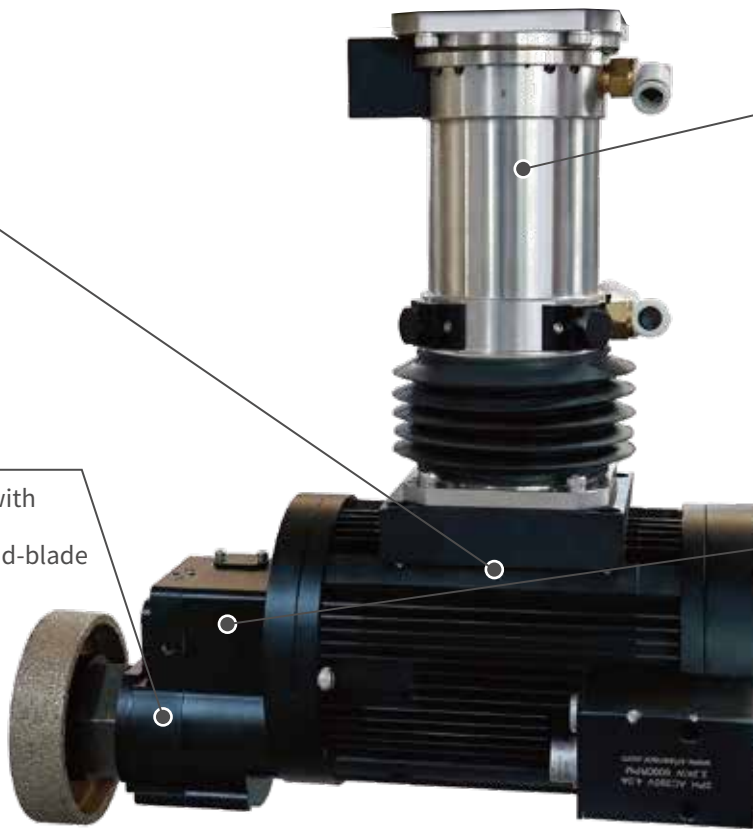

Advantage

01

Floating force control

Integrated iGrinder®
Superior floating force control function
The polishing effect is better

02

Gravity compensation

Polishing in any posture
All can maintain constant force grinding Pressure

03

Eccentric Spindle

Offset output shaft
avoids interference between the motor and workpiece

04

High-speed spindle

2.2kw/8000rpm
Gearbox reduction ratio 2:1
rated output torque 7Nm
maximum abrasive speed 4000rpm.

Application



Parameter

Weight	Force range	Accuracy	Floating Range	Displacement	Measuring Accuracy
18kg	0-300N	+/-1.5N	0-25mm		0.01mm

*The product is subject to the actual sample. SRI reserves the right to improve the appearance and design of the product.

iCG11

Number:iCG11

Interchangeable Force-controlled Straight Grinder

Performance

Floating force control

Integrated iGrinder®
Superior floating force control function
The polishing effect is better

A variety of knife heads

It can be equipped with sandpaper discs, louvers and thousand-blade wheels
Grinding wheels, milling cutters, etc

High-speed spindle

1.3kw
3000rpm

An automatic tool changer is optional

Integrated automatic tool changing system
The production line is more flexible

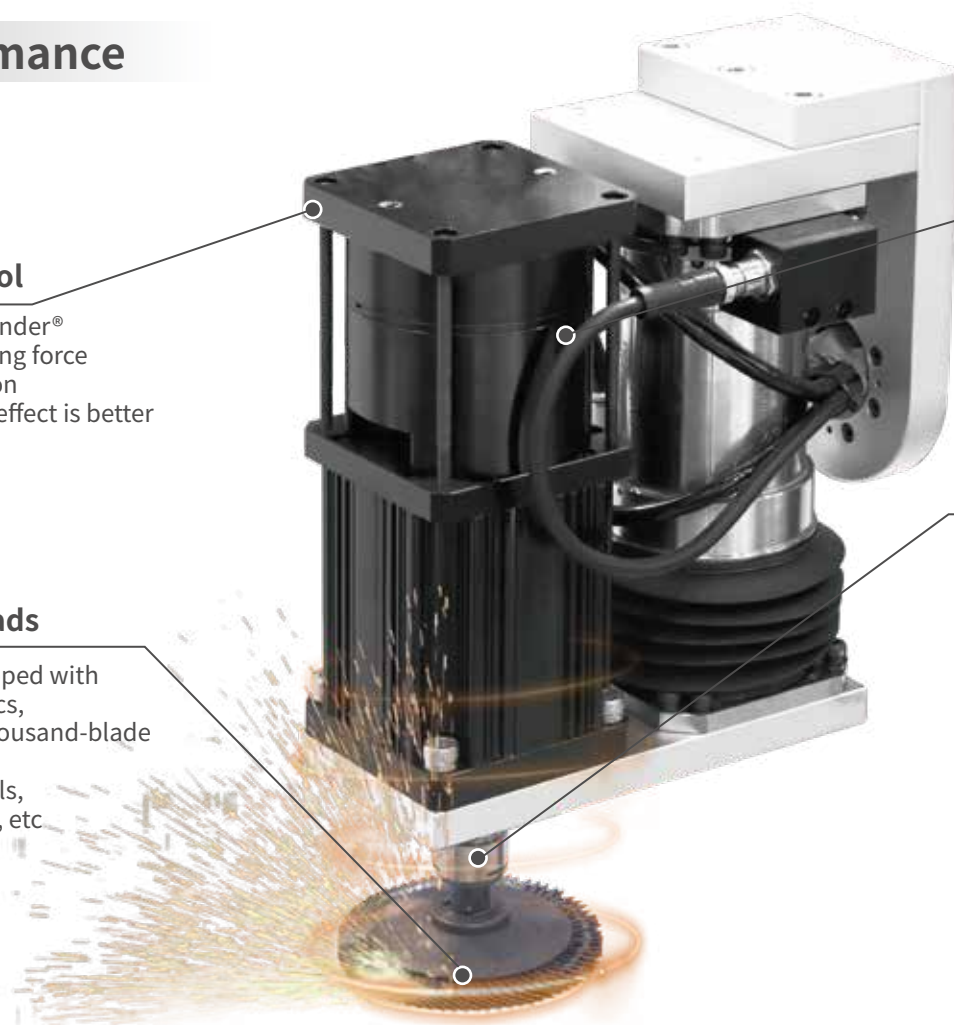

Advantage

01

Floating force control

Integrated iGrinder®
Superior floating force control function
The polishing effect is better

02

Gravity compensation

Polishing in any posture
All can maintain constant force grinding Pressure

03

Double abrasive design

One spindle solves two processes
The return on investment has doubled

04

High-speed spindle

1.3 kw / 3000 RPM
Rated speed: 3000rpm
Max speed: 6000rpm

Application



Parameter

Weight	Force range	Accuracy	Floating Range	Displacement	Measuring Accuracy
12.5kg	0-300N	+/-1.5N	0-25mm		0.01mm

*The product is subject to the actual sample. SRI reserves the right to improve the appearance and design of the product.

Intelligent Floating Grinding Head for Vehicles

Performance

Air-cut and power-off protection

Special protection structure, when the main power supply and gas source are suddenly turned off, automatic protection can be activated to prevent damage to the car body.

Abrasive Wear Compensation

Integrated displacement sensor to intelligently detect and compensate for abrasive wear.

Floating force control

Integrated iGrinder® Superior floating force control function The polishing effect is better

SEW motor

Dust cover

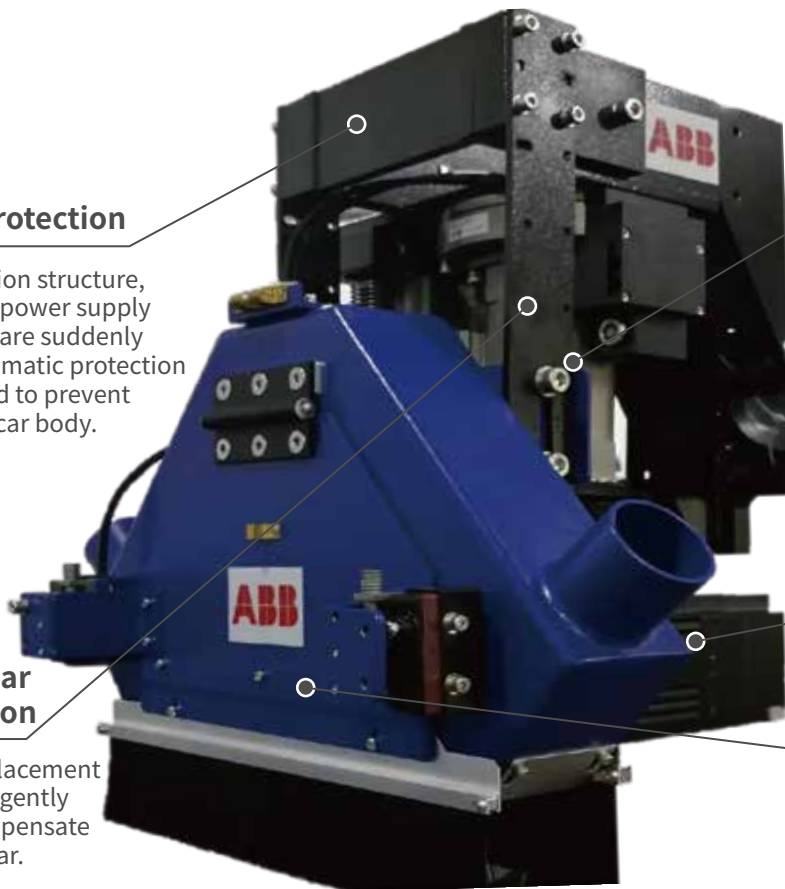

Advantage

01

Floating force control

Integrated iGrinder® Superior floating force control function The polishing effect is better

02

Gravity compensation

Polishing in any posture All can maintain constant force grinding Pressure

03

Air-cut and power-off protection

Special protection structure, when the main power supply and gas source are suddenly turned off, automatic protection can be activated to prevent damage to the car body.

04

Abrasive Wear Compensation

Integrated displacement sensor to intelligently detect and compensate for abrasive wear.

Application



Jointly developed with ABB Specifically designed for laser weld grinding applications on car roofs

Parameter

Weight	Force range	Accuracy	Floating Range	Displacement Measuring Accuracy
20kg	0-200N	+/-1N	0-35mm	0.01mm

*The product is subject to the actual sample. SRI reserves the right to improve the appearance and design of the product.

iBG01

Number:iBG01

Small Intelligent Force-controlled Belt Machine

Performance

Belt change

Floating force control

Integrated iGrinder®
Superior floating force control function
The polishing effect is better

Belt tension compensation

The grinding pressure is controlled by the iGrinder, and the belt tension does not affect the grinding force.

Grinding Amount Detection

Integrated displacement sensor that can automatically detect grinding amount.



Advantage

01

Floating force control

Integrated iGrinder®
Superior floating force control function
The polishing effect is better

02

Auto Belt Change

Specially designed for automatic abrasive belt replacement.
One belt sander for multiple processes.

03

Belt Tension compensation

The grinding pressure is controlled by the iGrinder, and the belt tension does not affect the grinding force.

04

Grinding Amount Detection

Integrated displacement sensor that can automatically detect grinding amount.

Application

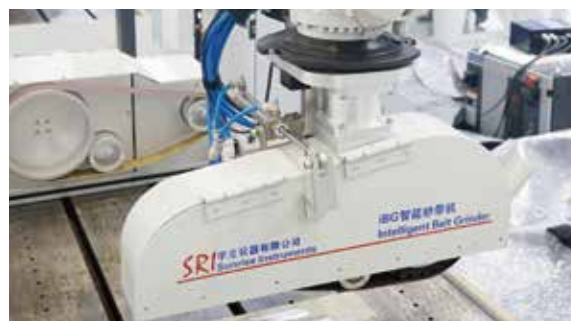

Parameter

Weight	Force range	Accuracy	Floating Range	Displacement	Measuring Accuracy	Belt Grinding Capability
26kg	0-200N	+/-1.5N	0-25mm		0.01mm	2-3kg stainless steel material

*The product is subject to the actual sample. SRI reserves the right to improve the appearance and design of the product.

iBG51

Number:iBG51

Large Intelligent Force Control Belt Machine

Performance

Multiple Abrasive Belt Design

Two belts included. One belt machine for more processes.

Grinding Amount Detection

Integrated displacement sensor
Intelligent detection of grinding volume

Vacuum cleaner

The grinding dust and debris can be collected.

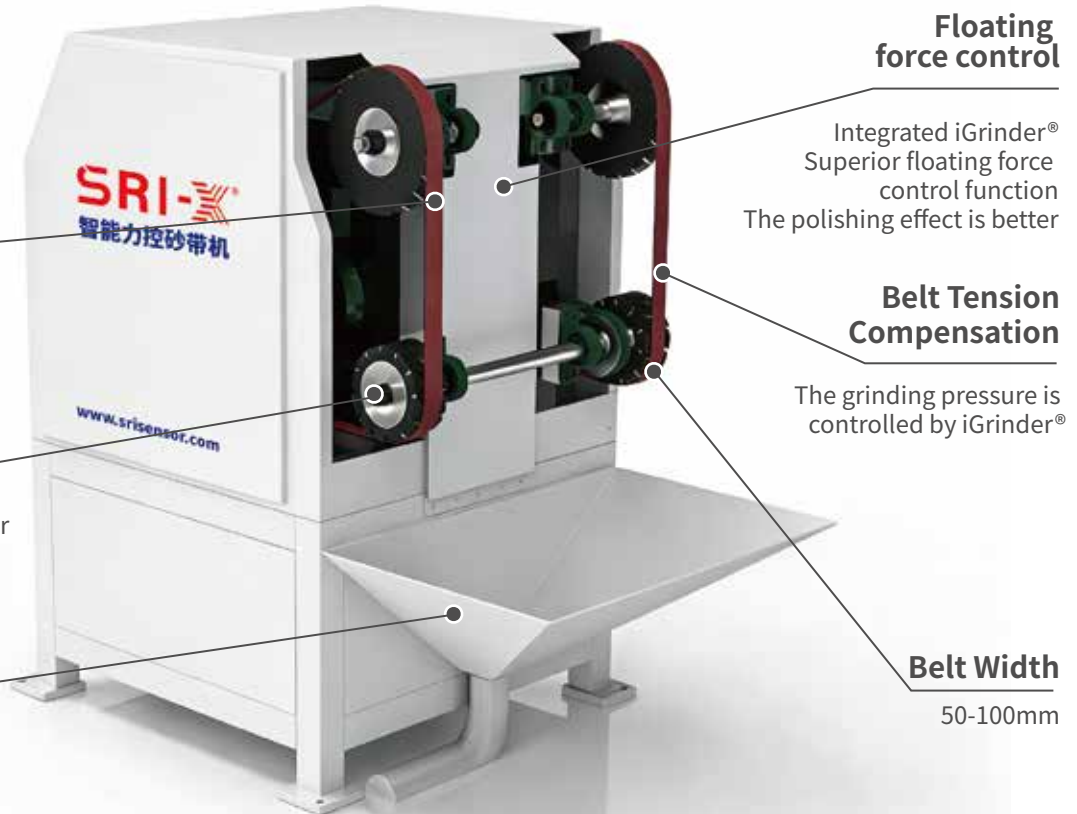

Floating force control

Integrated iGrinder®
Superior floating force control function
The polishing effect is better

Belt Tension Compensation

The grinding pressure is controlled by iGrinder®

Belt Width

50-100mm

Advantage

01

Floating force control

Integrated iGrinder®
Superior floating force control function
The polishing effect is better

02

Multiple Abrasive Belt Design

Two belts included.
One belt machine for more processes.

03

Belt Tension compensation

The grinding pressure is controlled by the iGrinder, and the belt tension does not affect the grinding force.

04

Grinding Amount Detection

Integrated displacement sensor that can automatically detect grinding amount.

Application



Parameter

Power	Maximum Line Speed	Belt Width	Speed	Floating Amount	Displacement Measuring Accuracy	Constant Force Range	Constant Force Accuracy
5.5kw	30m/s	50-100mm	2900rpm	0-35mm	0.01mm	30-300N	+/-3N

*The product is subject to the actual sample. SRI reserves the right to improve the appearance and design of the product.

iPG01

Number:iPG01

Force Control Polishing Machine

Performance

Grinding Amount Detection

Integrated displacement sensor that can automatically detect grinding amount.

Double Output Shaft Design

Polishing machine has double output shaft with two polishing wheels.

Floating force control

Integrated iGrinder® Superior floating force control function
The polishing effect is better

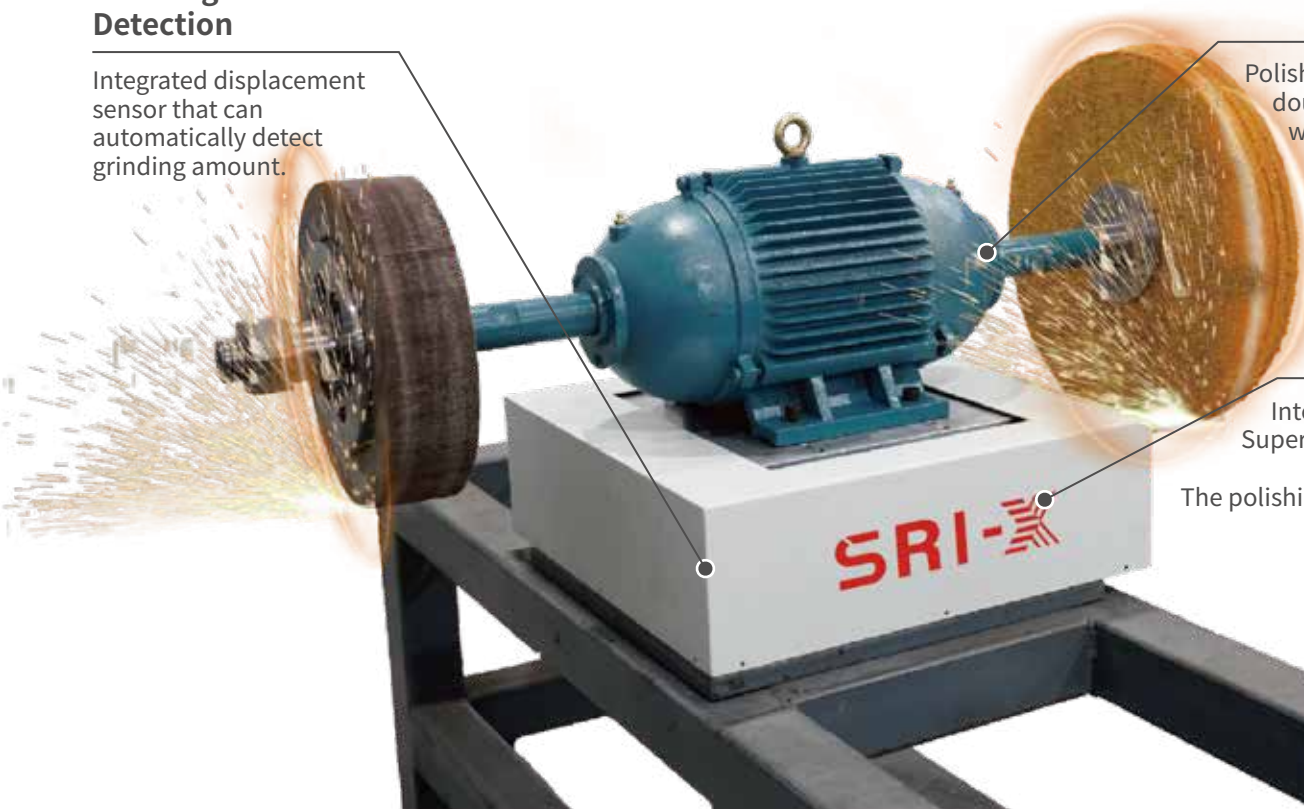

Advantage

01

Floating force control

Integrated iGrinder® Superior floating force control function
The polishing effect is better

02

Double Output Shaft Design

Polishing machine has double output shaft with two polishing wheels.

03

Floating force control

Integrated iGrinder® Superior floating force control function
The polishing effect is better

04

High-speed spindle

5.5kw/2800rpm

Application



Parameter

Power	Maximum Speed	Floating Amount	Displacement Measuring Accuracy	Constant Force Range	Constant Force Accuracy
5.5kw	2800rpm	0-35mm	0.01mm	20-200N	+/-2N

*The product is subject to the actual sample. SRI reserves the right to improve the appearance and design of the product.



iGrinder[®]

Radial Floating Force Control

Within the allowable radial float range, iGrinder[®] always maintains a constant radial output force. The floating force is proportional to the air supply pressure and pressure adjustment is realized by a precision pressure regulation valve.

M5302S

Number:M5302S

Interchangeable Radial Floating Head

Performance

Radial Float Range

±6°

Automatic tool change

Integrated automatic tool change function. The production line is more flexible

Communication Method

RS232, PROFINET



High-speed spindle

2.2kw; 8000rpm spindle. Drives a variety of abrasives

Floating force control

Radial constant force floating, gravity compensation, more convenient debugging, more stable production line process

Advantage

01

Floating force control

Integrated iGrinder® Superior floating force control function The polishing effect is better

02

Gravity compensation

Polishing in any posture All can maintain constant force grinding Pressure

03

Protection Class

IP60. Suitable for harsh environments

04

High-speed spindle

2.2kw/8000rpm

Application



Parameter

Weight	Force Range	Accuracy	Radial Float Range	Abrasive Maximum Outer Diameter	Protection Class	Communication Method
23kg	20-80N	+/-8N	±6°	150mm	IP60	RS232, PROFINET

*The product is subject to the actual sample. SRI reserves the right to improve the appearance and design of the product.

M5302T1

Number:M5302T1

Axial Radial Floating Head

Performance

Automatic tool change

Integrated automatic tool change function. The production line is more flexible

A variety of knife heads

It can be equipped with sandpaper discs, louvers and thousand-blade wheels
Grinding wheels, milling cutters, etc

High-speed spindle

2.2kw/8000rpm

Floating force control

Floating force control: 30N/mm
Floating range: ± 8 mm

Axial Radial Floating Force

Floating force control: 20 - 80 N
Floating range: $\pm 6^\circ$



Advantage

01

Floating force control

Integrated iGrinder® Superior floating force control function
The polishing effect is better

02

Axial Radial Floating Force

Axial Floating Force:30N/mm
Radial Floating Range: ± 6 degree

03

Protection Class

IP60. Suitable for harsh environments

04

High-speed spindle

2.2kw/8000rpm

Application



Parameter

Weight	Force Range	Accuracy	Radial Float Range	Abrasive Maximum Outer Diameter	Protection Class	Communication Method
23kg	10-80N	+/-8N	$\pm 6^\circ$	150mm	IP60	RS232、PROFINET

*The product is subject to the actual sample. SRI reserves the right to improve the appearance and design of the product.

M5134N

Number:M5134N

Floating Deburring Tool

Performance

Floating Structure

Axial and radial floating. The floating force can be controlled by a precision pressure regulating valve

Basic Information

Power 300w; no-load speed 3600rpm; air consumption 90L/min; chuck size 6mm or 3mm

Protection Class

Special dustproof and waterproof design for harsh environments

Force Control Range

Radial float +/-6° 0-100N. Adjustable float force through precision pressure regulator

Deburring Tool

Deburring tools can be selected from reciprocating files, rotary files, scrapers, thousand impellers, diamond grinding rods, resin grinding rods, etc.



Advantage

01

Clamable cutting tools

Tool diameter 6mm/3mm

02

Basic Information

Power 300w; no-load speed 3600rpm; air consumption 90L/min;

03

Force Control Range

Radial float +/-6° 0-100N. Adjustable float force through precision pressure regulator

04

Protection Class

Special dustproof and waterproof design for harsh environments

Application



Parameter

Weight	Radial Float Range	Force Range	Force Range	Power	Rotational speed	Air Consumption	Chuck size
4.5kg	+/-6°	0-100N	0-20N	300W	3600rpm	90L/min	6mm/3mm

*The product is subject to the actual sample. SRI reserves the right to improve the appearance and design of the product.

M5933N

Number:M5933N

Floating Deburring Tool

Performance



Advantage

- 01** **Radial Floating Range**
±6°
- 02** **Automatic Tool Change**
Pneumatic, above 0.5MPa
- 03** **Floating force control**
Integrated iGrinder® Superior floating force control function The polishing effect is better
- 04** **Main shaft**
Power:400W Rated Speed:20000rpm Minimum Speed:3000rpm

Application



Parameter

Weight	Radial Floating Range	Radial Floating Force	Rated Speed	Minimum Speed	Clampable Tool Diameter	Power	Spindle Cooling
6kg	+/-6°	8-100N	20000rpm	3000rpm	3-7mm	400W	Air cool

*The product is subject to the actual sample. SRI reserves the right to improve the appearance and design of the product.



iGrinder[®]

Grinding tools and related products

iGrinder®

Grinding tools and related products

Electric spindle tool holder

The spindle tool holder designed and developed by SRI is used in conjunction with SRI electric spindle. It can achieve automatic tool changing.



Model	Description
M5913C-41	Straight grinding machine tool holder, louver disc
M5308S35A12-40	Louwer disc tool holder - compatible with 2.2KW end shaft output
M5302S-95	SRI ER11 chuck holder, clamping range 3-6mm
M5302S-75	SRI ER20 chuck tool holder, clamping range 1-13mm
M5936A-30	SRI direct grinding milling cutter shank
M5913R-02	Angle grinder handle, louver disc
M5913E2-10	SRI straight mill tool holder, sandpaper tray,5 inches

Automatic tool changer magazine

It is used to store spare tool holders, facilitating the automatic tool change of the spindle, providing more grinding/polishing process options, and enhancing the flexibility of the production line. Standard 4 tool positions, equipped with tool position detection sensors, and the number of tool positions can be customized. Equipped with a dust cover, I/O control is easy to switch on and off. The dust cover is standard with a tool magazine bracket, which is convenient for fixing to the project site



Model	Description
M5913F2A	SRI tool holder tool changer magazine - 5 tool positions, with dust cover and tool position detection
M5913F2B	ISO20 tool holder changer magazine - 5 tool positions, with dust cover and tool position detection
M5913F2C	ISO30 tool holder changer magazine - 5 tool positions, with dust cover and tool position detection
M5961M1-60	Automatic tool changer with dust cover and tool position detection
M5961G1-66	Automatic tool changer with dust cover and tool position detection
M5286H1A-400	Automatic tool changer with dust cover and tool position detection

*The product is subject to the actual sample. SRI reserves the right to improve the appearance and design of the product.

iGrinder®

Grinding tools and related products

Automatic sandpaperchanging warehouse

It is used for storing spare sandpaper, facilitating automatic sandpaper replacement, providing more polishing process options, and enhancing the flexibility of the production line. The sandpaper is automatically stripped off and stored in the discarded sandpaper bin. There are two standard spare sandpaper positions, and the number of spare sandpaper positions can be customized. Equipped with sandpaper detection function, it can identify whether the sandpaper is missing, including circular and square sandpaper positions, and supports customization.



Model	Description
M5952V	2. Sandpaper position, sandpaper replacement warehouse, including sandpaper stripping and spare sandpaper inspection
M5961A2	8 Sandpaper positions, sandpaper replacement warehouse, including sandpaper stripping and spare sandpaper inspection

Electrical control cabinet

Standard configuration of SRI iGrinder® control cabinet



Model	Description
M8462G	Standard configuration

*The product is subject to the actual sample. SRI reserves the right to improve the appearance and design of the product.

CONTACT US



★ Main Office ● Office ● Customers



China Main Office

Address: No.176, Gaoji Rd, Songjiang District, Shanghai, China
Tel: +86-21-6127-6380
Email: sri@srisensor.com



USA Office

Address: 8534 N Canton Center Rd, Canton, MI 48187, USA
Tel: +1-947-214-0359
Email: marcus@srisensor.com



Taiwan (Sales)

MEMS TECHNOLOGY CORP.
Address: 5-9, 3rd Floor, No. 6, Section 1, Zhongxing Road, Wugu District, New Taipei City 248312, Taiwan
Tel: ++886-2-8976-9066 #223
Mobile: +886-2-8976-9099
Email: john.pai@memstec.com.tw



KOREA (Sales)

Kyoung-Tae Min, KTINC
Address: Rm 1406, ACE Pyeongchon Tower 361 SIMIN-DAERO, DONGAN-GU, ANYANG-SI, GYEONGGI-DO, S.KOREA.
Mobile: 010-8650-8498
Tel: +31-383-8498
E-mail: info@ktinc.kr



Japan (Sales)

K Futami, JASTI CO., LTD
Address: 2-4-3, Miyoshi, Koto-ku, Tokyo, 135-0022, Japan
Tel: +81-(0)3-5245-3661
Email: k_futami@jasti.co.jp